

maxx

orthopedics



FREEDOM[®] PCK[®] REVISION KNEE SYSTEM **Surgical Technique**

Contents

Overview	3
Preoperative Planning	4
Incision and Exposure	5
Implant Removal	5
Stem Configuration	6
Quick Steps and Tips	7
Stemmed Tibial Preparation	11
Resection of the Proximal Tibia	12
Tibial Augment Preparation	13
Tibial Baseplate Positioning.....	13
Keel Preparation	15
Femoral Preparation	16
Sizing the Femur	16
Reaming IM Canal	16
Distal Femoral Cut	18
A/P Cutting Block Positioning without Femoral Offset	20
A/P Cutting Block Positioning with Femoral Offset	21
PCK Box Cut Guide & Boss Reaming - without Femoral Offset.....	23
PCK Box Cut Guide & Boss Reaming – with Offsetting Femoral	25
Patellar Preparation	27
Trialing	28
Stemmed Tibial Components	28
Femoral Components	29
Tibial Insert.....	30
Trial Reduction & Gap Balancing	30
Final Implantation	31
Final Implantation: Stemmed Tibial Assembly	31
Tibial Stem Fixation – Cemented or Press-Fit	32
Final Implantation: Femoral Assembly	33
Femoral Stem Fixation – Cemented or Press-Fit	34
Final Implantation: Poly Insert	35
Final Implantation: Patella.....	35
Incision Closure	35
Set Configurations/Ordering Information	35

Overview

Basic principles of total knee replacement surgery should be followed throughout the procedure. The surgeon must pay close attention to balancing the flexion and extension gaps, accurately sizing the femoral, tibial, and patellar components, positioning the femoral component in appropriate external rotation, removing excessive osteophytes from the posterior condyles, maintaining the joint line, and implanting the final components using modern cementing techniques.

Preparation of the femur, tibia, and patella is independent and can be performed in any order, based on surgeon preference. The principles of measured resection (replacing removed bone with equal amounts of implant) are used to provide this versatility during the operation. When trialing the implants, it is recommended that the surgeon assess overall joint line and alignment, extension angle, varus/valgus stability, flexion angle, patellofemoral tracking, and anterior/posterior stability. The surgical technique outlined is specific to Freedom® Primary PCK® Knee System and Freedom PCK Knee System.

Key Features: Progressive Constraint Kinematics

Patented Trapezoidal box provides varying constraint - high constraint (extension) to less constraint (flexion)



B > A

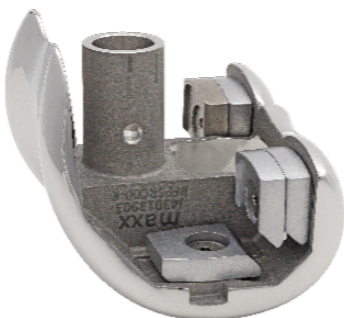

Canal filling stems for press-fit or cemented fixation

360° rotating femoral and tibial offset junction provides optimal canal filling and fixation for immediate rigid fixation and resistance to torsional movements

Constrained poly with pre-assembled securing pin

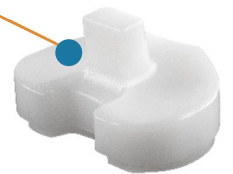

Low profile tibial baseplate



Freedom® PCK® Revision Knee System

Ti-alloy femoral stems

7.5mm-20mm diameters
(22, 24mm – special order)
40mm, 75mm, 100mm,
150mm lengths

Offset couplers (optional)

TiNbN coating designed
for patients with metal
hypersensitivity
(Titan™ ONLY)

Ti-alloy tibial stems

7.5mm-20mm diameters
(22, 24mm – special order)
40mm, 75mm, 100mm,
150mm lengths

Stems for either
Press-Fit or
Cementing

Thin anterior flange

Ti-alloy femoral
augments

UHMWPE insert

Ti-alloy tibial augments
(stackable)

PREOPERATIVE PLANNING

Preoperative radiographs can be used to anticipate aspects of the surgical procedure including implant sizing, stem extension length and diameter, quality of bone stock, and alignment of bone cuts. X-rays should include coronal and sagittal views of the operative knee in full extension. You may contact your Maxx Orthopedic representative for x-ray templates. Templates are available for all digital platforms.

The angle between the mechanical and anatomic axes of the femur should be reproduced intraoperatively. The tibial component should be positioned perpendicular to the mechanical axis of the tibia in the frontal plane. Implant sizing must be determined intraoperatively as x-rays only provide an approximation.

INCISION and EXPOSURE

Prior to incision, the superior pole of the patella is marked with the knee flexed at 30°. The tibial tubercle is identified and marked. **An anterior midline longitudinal incision is made** from a point slightly proximal to the superior pole of the patella passing just medial to the tibial tubercle at its distal margin. If significant tension is noted along skin edges, the incision should be extended.

- **Visualize the extensor mechanism without undermining the medial and lateral skin flaps.**
- **Use a surgical marker to mark the medial para patellar arthrotomy line,** starting from the medial edge of the extensor mechanism along the medial border of the patella to the medial edge of the patella tendon.

Be cautious not to transect the quadriceps in thinner patients with a small quadriceps tendon, as this could compromise postoperative rehabilitation protocols.

- **Perform the medial parapatellar arthrotomy.** When possible, follow the pre-existing scar from the primary procedure.
- **Extend the leg and remove some of the fat pad** under the patella tendon.
- **Remove osteophytes** along the margin of the patella.
- **Retract the patella laterally** with the knee in extension and release the patellofemoral ligaments.
- **Perform an abbreviated medial release** of the proximal soft tissue attachments to the proximal tibia in standard fashion.
- **Place retractors along the medial and lateral sides of the tibia for full visualization.**



IMPLANT REMOVAL - Existing Hardware

Preserve as much bone stock as possible when removing the primary implants. It is generally beneficial to remove the femoral implant first, as this can improve access to the tibial components. A variety of tools can be utilized to disrupt the implant-bone interface, including osteotome, reciprocating saw, and dedicated extraction instruments. Remove any bone cement that remains after extracting the primary implant.

STEM CONFIGURATION

The following tables outline the available stem extension offerings for the Freedom PCK Revision Knee System, organized by stem diameter and length. To improve clarity, stems are categorized into fluted and non-fluted designs. Sizes marked with an asterisk (*) indicate special order items that may not be routinely stocked and should be requested through Maxx Orthopedics in advance of surgical scheduling. All stem configurations listed below are compatible with either press-fit or cemented fixation techniques, allowing the surgeon to select the appropriate application based on intraoperative findings and clinical preference.

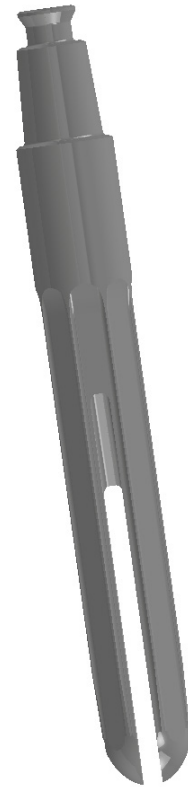
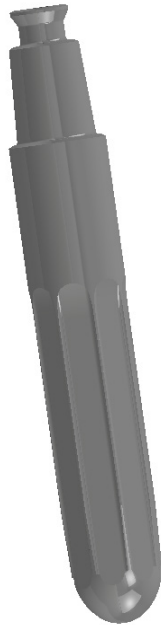

Stems without Flutes

Stem Diameter	Stem Length			
	40mm	75mm	100mm	150mm
7.5mm		X	X	X
9mm	X	X	X	X
10.5mm		X		
12mm	X	X		
13.5mm		X		
15mm	X	X		
16.5mm		X		
18mm		X		
20mm		X		
22mm*		X		
24mm*		X		

Stems with Flutes

Stem Diameter	Stem Length			
	40mm	75mm	100mm	150mm
7.5mm				
9mm				
10.5mm			X	X
12mm			X	X
13.5mm			X	X
15mm			X	X
16.5mm			X	X
18mm			X	X
20mm			X	X
22mm*			X	X
24mm*			X	X

Freedom PCK Revision Knee System - Quick Steps

Stemmed Tibial Preparation

REAMING IM CANAL

- Open canal to accommodate stem/optional offset
- Reference reaming depth chart based on stem length and offset
- Use sharp-tipped distal reamer; ream under power or manually
 - Ream to depth where marking reaches proximal tibial cut level
 - Increase reamer size in 0.5mm steps to reach cortical contact
 - Match reamer/stem size for press-fit; oversize by 0.5–1.5mm if cementing
- Leave reamer in place as reference for later instrumentation

RESECTION OF THE PROXIMAL TIBIA

- Assemble IM tibial cutting guide (TCG) and place over reamer
- Adjust TCG jig vertically using cam lever and thumb knob
- Use angel wing to assess resection depth and augmentation need
- Pin TCG to tibia using long pins; remove cutting guide (TCG)
- Perform tibial resection through jig cutting slot using saw
- Use ± 2 mm pin holes to adjust depth; assess for medial/lateral augmentation

TIBIAL AUGMENT PREPARATION

- If no augment needed, skip to Tibial Baseplate Positioning
- Pin jig in 'ZERO' holes; resect using +5mm or +10mm slot for augments
 - For 15mm, re-pin jig to +5mm holes and resect via +10mm slot
- Size tibial baseplate for maximum coverage, centered or offset
- Attach corresponding augments to offset guide plate with augment pins
- Place guide plate over distal reamer and pin in place

TIBIAL BASEPLATE POSITIONING

- Use central dial over distal reamer for centered placement
- If needed, rotate offset dial (4mm or 6mm) for better coverage
- Secure guide plate to tibia with long pins
- Note offset position using laser markings

KEEL PREPARATION

- Insert tibial broach housing into offset guide plate
 - Ream with entry reamer to broach housing level (adjusted for offset)
- Insert tibial broach until seated; use slap hammer to extract if needed
- Remove all instrumentation; tibia is now ready for trialing

Femoral Preparation

SIZING THE FEMUR

- Use removed primary femoral component as initial size reference
- Alternatively, use femoral profile guides to assess optimal fit
- Select revision femoral component size that restores proper anatomy
- Confirm sizing against resected distal femur and patellar tracking

REAMING THE IM CANAL

- Remove cancellous bone from canal to allow stem passage
- Select reamer depth using femoral reaming chart based on size and stem length
 - Orient reamer slightly anterior; ream canal until target depth marking aligns with distal femur surface
 - Increase reamer diameter in 0.5–1.5mm increments until cortical contact is achieved
 - For press-fit: Match reamer size 1:1 to stem
 - For cemented: Oversize reamer by 0.5–1.5mm over stem diameter
- Adjust reaming if femoral offset is later required

Femoral Preparation - Continued

DISTAL FEMORAL CUT

- Leave final reamer in femoral canal; slide 6° valgus block in place
- Attach DFCG jig to angle block; lay block flat against femur
- Pin DFCG jig through 0mm holes; use angel wing to assess cut level
 - Adjust depth ± 2 mm or use U-plate for 5/10/15mm augmentation
- Remove reamer if interfering, then perform distal femoral cut
- Augments can be asymmetric; max of 3 distal augments per side

A/P CUTTING BLOCK POSITIONING WITHOUT FEMORAL OFFSET

- Insert final reamer and T-handle for stability
- Select proper femoral A/P cutting block (size-specific)
- Attach distal augments if used; secure with augment pin
- Slide A/P block with oblong insert over reamer
- Use angel wing to check for anterior notching
- Pin block to femur if alignment is correct

KEEL PREPARATION

- Insert tibial broach housing into offset guide plate
 - Ream with entry reamer to broach housing level (adjusted for offset)
- Insert tibial broach until seated; use slap hammer to extract if needed
- Remove all instrumentation; tibia is now ready for trialing

A/P CUTTING BLOCK POSITIONING WITH FEMORAL OFFSET

- Verify reamer depth is adequate for offset; ream more if needed
- Attach required augments to offset A/P cutting block
- Position block over reamer using 4mm offset dial
- Rotate dial for optimal A/P and M/L positioning
- Use angel wing to check anterior resection line
- Pin guide in place using long pins; remove dial and guide
- Mount metal A/P cutting block using same pins
- Perform anterior and posterior cuts (use +5/+10mm slots if needed)

PCK BOX CUT GUIDE & BOSS REAMING – WITHOUT FEMORAL OFFSET

- Select BCG that matches femoral size; attach distal augments if needed
- Add femoral drill housing guide to BCG face; confirm correct laterality
- Slide BCG assembly over reamer and pin anteriorly
- Drill for boss reamer until contact with guide housing
- Perform box and chamfer cuts using sagittal and reciprocating saws

PCK BOX CUT GUIDE & BOSS REAMING – WITH FEMORAL OFFSET

- Select and assemble BCG with matching offset plate and augment
- Insert 4mm offset dial and seat BCG flush with femur
- If anterior gap is noted, understand recut and cement fill will be needed
- Attach drill housing and drill for boss reamer to 100mm depth mark
- Remove drill components; make box and chamfer cuts

Patellar Preparation

- Evert patella and flex knee to 30°
- Measure thickness with caliper; resect accordingly
- Use drill guide to size and drill 3 holes
- Place trial and range knee to confirm tracking

Trialing

STEMMED TIBIAL COMPONENTS

- Select trial tibial tray and stem extension based on prior planning
- If no offset: Hand-tighten stem directly into tibial tray keel
- If offset needed:
 - Hand-tighten 4mm or 6mm tibial offset adapter into keel
 - Align letter on offset with keel number
 - Secure offset to tray using 15mm headed screw with star driver
 - Hand-tighten stem into offset adapter
- Assemble tray with augments if required, stacking up to 3 augments per side if necessary
- Secure augments to trial tray with appropriate length screws

FEMORAL COMPONENTS

- Select femoral trial component and stem extension based on prior planning
- If no offset: Hand-tighten stem directly into femoral boss
- If offset needed:
 - Hand-tighten 4mm offset adapter into femoral boss
 - Align letter on offset with boss marking
 - Insert and fully tighten junction screw using 2mm hex
 - Hand-tighten stem into offset adapter
- Assemble femoral trial with appropriate distal and/or posterior augments if needed
- Secure augments with trial augment pins

TIBIAL INSERT

- Select tibial insert trial that matches:
 - Articular top surface = femoral size
 - Modular bottom surface = tibial tray size
- Choose insert thickness from 11mm to 31mm based on required joint space
- Insert trial insert into tray between femoral and tibial constructs

TRIAL REDUCTION AND GAP BALANCING

- Perform trial reduction with all trial components fully assembled
- Evaluate extension gap, flexion gap, varus/valgus stability, and patellar tracking
- Confirm anterior/posterior stability through range of motion
- Make intraoperative adjustments if needed:
 - Use thicker/thinner inserts to adjust gaps
 - Modify augments or perform selective soft tissue releases
- Once satisfactory, document the full implant configuration:
 - Femoral size, stem, offset, augment details
 - Tibial size, stem, offset, augment details
 - Tibial insert size and thickness
 - Patellar size (if resurfacing)

Final Implantation

STEMMED TIBIAL ASSEMBLY

- Remove keel plug and top center plug using 2mm hex
- If no offset: Hand-tighten stem directly into tibial tray keel
- If using offset:
 - Insert 4mm or 6mm tibial offset adapter and align letters/numbers
 - Secure with 15mm headed screw using star driver
 - Hand-tighten stem into offset adapter
- Secure tibial augments to tray using screws from the augment set
- Impact full construct together and prepare for implantation

FEMORAL ASSEMBLY

- Remove boss plug using 2mm hex
- If no offset: Hand-tighten stem directly into femoral boss
- If using offset:
 - Insert 4mm offset adapter into boss and align markings
 - Secure offset to femur using set screw via 2mm hex
 - Hand-tighten stem into offset adapter
- Attach distal and/or posterior augments as needed using 6.5mm headed screws
- Impact final construct together; verify fit and augment engagement

POLY INSERT

- Insert final poly insert at a 45° angle, engaging posterior edge first
- Use tibial impactor to seat insert fully into the tray
- Lock insert in place with 2mm hex locking screw through the top of the tray

PATELLA

- Pulse lavage patellar bed and dry thoroughly
- Apply cement to both bone surface and implant undersurface
- Seat patella component firmly and remove excess cement
- Hold pressure until cement cures; ensure proper tracking
- Close incision in standard fashion, confirming final construct position

STEMMED TIBIAL PREPARATION

Reaming Intramedullary (IM) Canal

1. Remove cortical bone to accommodate the stem extension and optional offset junction.
2. Determine the reamer depth marking corresponding to the stem extension and optional offset junction combination to be implanted. (reference table below)
3. Ream the medullary canal with a sharp-tipped distal reamer (9mm) until the appropriate depth marking reaches the surface of the proximal tibia. Reamers may be driven by power or by hand with a T-Handle dependent on preference
4. Progressively increase reamer diameter incrementally until the desired cortical bone contact is achieved.

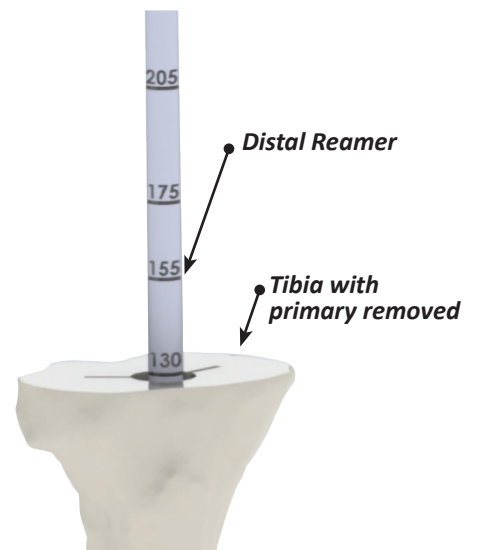

STEM LENGTH	REAMER DEPTH MARKING	
	With Offset	Without Offset
40mm	65mm	100mm
75mm	100mm	130mm
100mm	130mm	155mm
150mm	175mm	205mm

NOTE: Uncemented stems- Reamer and tibial stem size should match 1 to 1.
Cemented stems- Ream an additional 0.5mm- 1.5mm in diameter to allow room for cementation.

The reamed depth of the IM canal increases if the tibial component is to be offset, see Table above. If a tibial offset need is unknown or cannot be determined at this time, additional depth can be reamed later.

5. Subsequent instrumentation uses the 9mm shaft of the distal reamer as a positioning reference.

Resection of the Proximal Tibia

6. Assemble the IM tibial cutting guide (TCG) by inserting the reamer connector through the vertical body by depressing the **Button** as shown.
7. Place **TCG Jig** onto the **Jig Connector** with **Jig Lever** horizontally aligned. Lock TCG by rotating **Jig Lever** vertical.
8. Slide the reamer connector over the distal reamer to the osteotomy level.
9. Tighten the TCG jig against the anterior of the tibia using the ratcheting connection between the vertical body and reamer connector. It can be released and repositioned by depressing the **Button** in the vertical body.
10. Position **TCG Jig** by unlocking the **Cam Lever** for macro-adjustments. Use **Thumb Knob** for micro-adjustments.
11. Use an **angel wing** through the cutting slot to visualize resection depth and assess for **medial/lateral augmentation**. Reference **5mm markings** on the vertical body for guidance.

NOTE: If the proximal surface of the TCG jig is set at the same height as the proximal tibial surface, resection through the cutting slot will result in a minimum depth of 3mm at the anterior face of the tibia.

12. With the desired resection level set, pin the **TCG jig** to the tibia using **long pins**. Remove the **tibial cutting guide (TCG)** by releasing the **jig lever**, depressing the button on the side of the **vertical body**, and separating the guide from the pinned **TCG jig** and **reamer**).
13. The **distal reamer** and the pinned **TCG jig** should be the only instrumentation remaining at this point.
14. Remove the distal reamer, if needed and resect the tibia using an **oscillating saw** through the cutting slot in the **TCG jig**.
15. Resection depth can be further adjusted 2mm distally or proximally using the ± 2 mm pin holes in the **TCG jig**.
16. Assess the need for medial and/or lateral augmentation with the aid of an **angel wing**.

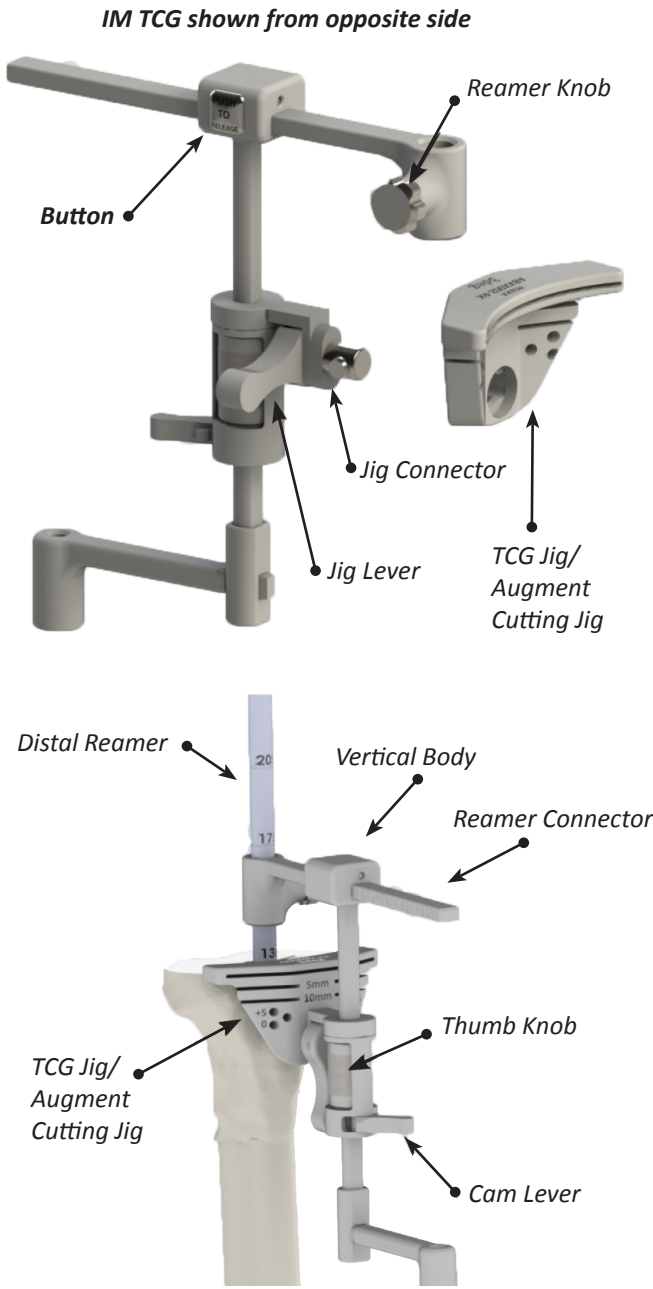

Tibial Augment Preparation

If No Tibial Augments are required, proceed to Tibial Baseplate Positioning portion of technique.

17. Resect the bone to accommodate the required number of tibial augments.

With the jig pinned in the 'ZERO' holes:

- For a 5mm augment, perform bone resection through the +5mm slot for a single augment.
- For a 10mm augment (two stacked 5mm augments), perform bone resection through the +10mm slot.

NOTE: For a 15mm augment, (three stacked augments), move the tibial augment cutting jig to the +5mm pin holes and perform bone resection through the +10mm slot, giving a total of 15mm of resection.

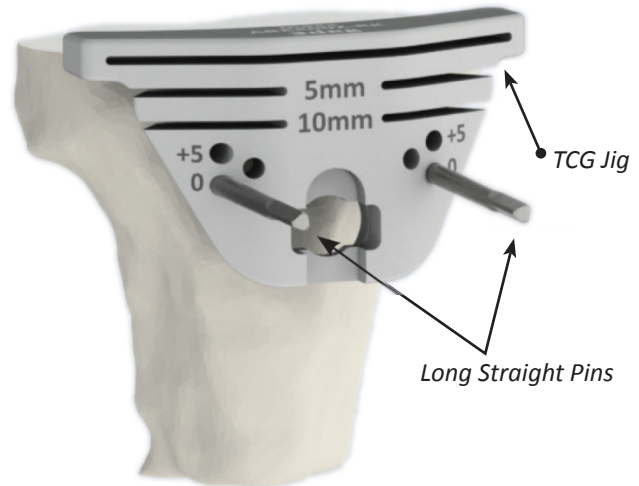

Tibial Augment Preparation

18. Size and position the tibial baseplate to achieve maximal coverage of the proximal tibial surface, either centered about the IM canal or offset by 4mm or 6mm. If removed for resection, reintroduce the distal reamer into the IM canal.

19. Select the appropriately sized tibial guide plate, which has bony support on all sides with no overhang.

20. If tibial augment cuts were made in the previous step, select the corresponding size and thickness of tibial guide plate augments (referred to as "augments" here) to attach to the underside of the tibial offset guide plate. Attach the augments with the appropriate length augment pin. If desired, hold the tibial offset guide plate with the tibial tray coupler.

21. For appropriate positioning, place the tibial guide plate over the distal reamer and against the resected proximal tibia.

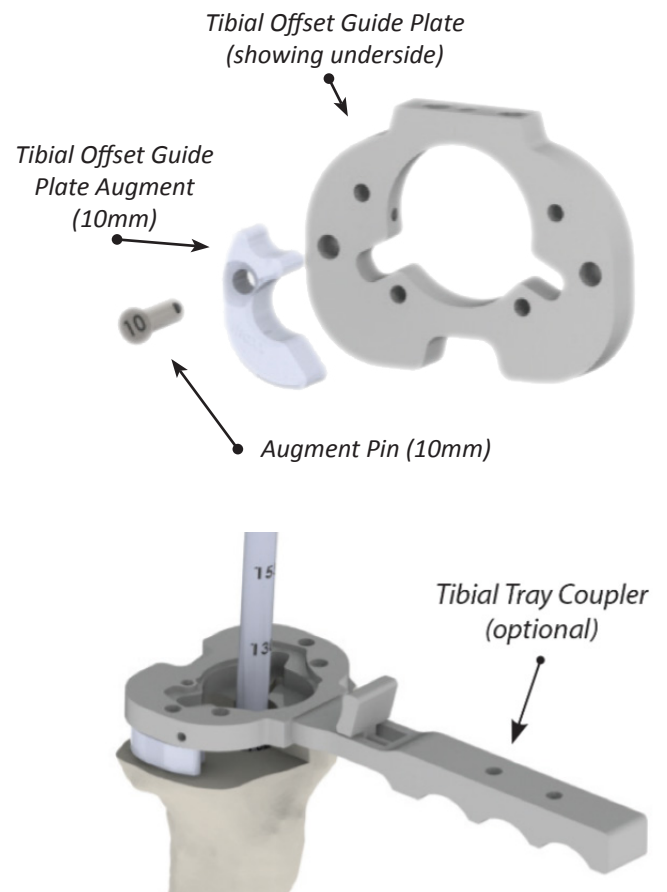

22. Next, slide the central dial (0mm) over the distal reamer and secure it in the recess of the tibial offset guide plate. Keep the underside of the tibial offset guide plate against the resected proximal tibia and slightly rotate it about the distal reamer to achieve maximum coverage.

Note: If coverage is optimal, secure the tibial offset guide plate to the tibia with long pins. In this case, the tibial guide plate is centered about the IM canal and therefore no tibial offset will be performed. Skip to **Keel Preparation** if adequate.

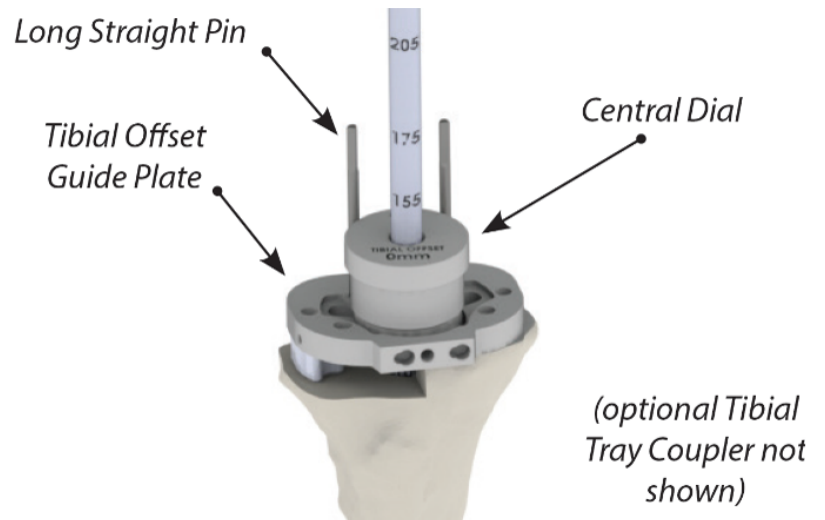

23. However, if tibial coverage is inadequate with the tibial guide plate positioned using the central dial, better coverage will be achieved through offsetting the tibial component with respect to the IM canal.

24. With the tibial guide plate positioned using the offset central dial (4mm or 6mm), secure the tibial guide plate to the tibia with long pins. Note the laser marking position of the offset as shown.

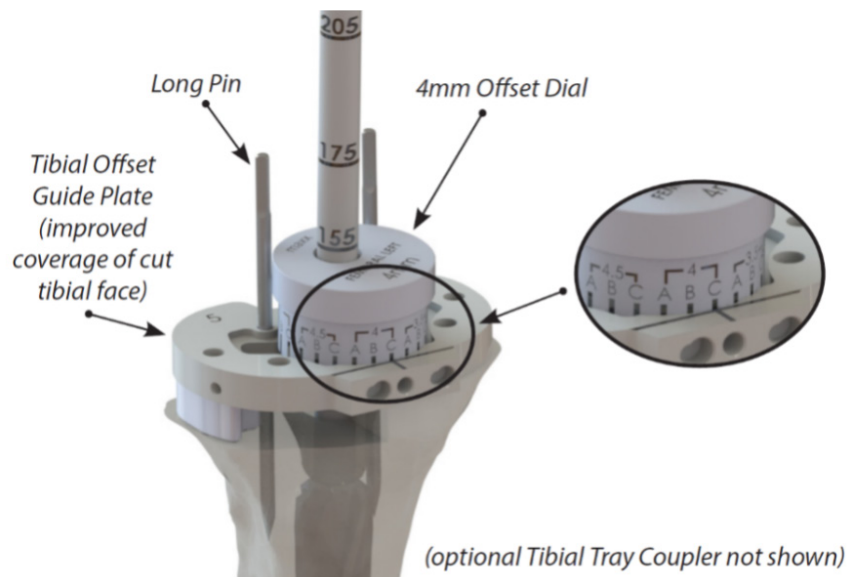

Femoral IM Reaming Depth:

PCK Size Sizes B and C		
Stem Length	Reamer Depth Marking	
	No Offset	With Offset
40mm	65mm	100mm
75mm	100mm	130mm
100mm	130mm	155mm
150mm	175mm	205mm

PCK Size E, F, and G		
Stem Length	Reamer Depth Marking	
	No Offset	With Offset
40mm	Mid-way between 65 and 100	Mid-way between 100mm and 130mm
75mm	Mid-way between 100 and 130	155mm
100mm	Mid-way between 130 and 155	175mm
150mm	Mid-way between 175 and 205	205mm + approx. 25mm

PCK Size H		
Stem Length	Reamer Depth Marking	
	No Offset	With Offset
40mm	100mm	Mid-way between 100mm and 130mm
75mm	130mm	155mm
100mm	155mm	175mm
150mm	205mm	205mm + approx. 25mm

NOTE: Uncemented stems- Reamer and tibial stem size should match 1 to 1.
Cemented stems- Ream an additional 0.5mm- 1.5mm in diameter to allow room for cementation.

The reamed depth of the IM canal increases if the femoral component is to be offset, see Table below. If a femoral offset need is unknown or cannot be determined at this time, additional depth can be reamed later.

Distal Femoral Resection

38. If deficient bone is present, remove only as much as necessary to accommodate distal femoral augmentation blocks. Ensure that all fibrous or sclerotic tissue is removed to establish a stable surface for resection and reconstruction.

39. Leave final reamer in place within the femoral canal to serve as a central reference shaft for instrumentation.

40. Slide the 6° valgus angle block over the distal reamer, ensuring it is properly oriented for the operative side.

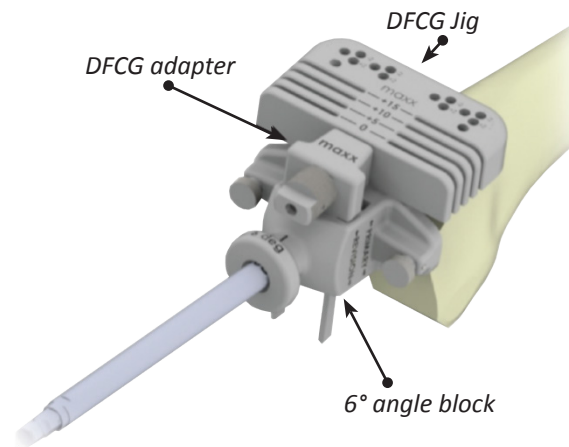

NOTE: The Freedom Knee® PCK femoral has a fixed 6° valgus angle.

41. Snap the **Distal Femoral Cutting Guide (DFCG) jig** onto the adapter and insert the adapter into the “Revision” slot of the 6° angle block.

42. Lay the 6° angle block flat against the distal femur to set the intended resection level.

43. Secure the DFCG jig to the femur using **long smooth pins** through the 0 mm holes.

44. Use the **angel wing** to visually assess the intended resection plane and evaluate the need for medial and/or lateral distal augments.

45. If desired, adjust the distal resection depth by **±2 mm** by pinning through the alternate pin holes on the DFCG jig.

46. When **both medial and lateral augments** are required, utilize a **U-plate** to elevate the resection plane. Insert the U-plate through the designated augment slots (+5, +10, or +15) on the jig, then lay it against the distal femur. Proceed to re-pin the jig to the femur with the U-plate in place.

47. Once the DFCG jig is securely pinned, **unscrew to detach the adapter** and remove the 6° angle block.

48. If bone remains in close proximity to or surrounding the distal reamer, remove the reamer prior to making the resection.

49. Using an oscillating saw, perform the distal femoral resection:

- If **no augmentation** is required, cut through the **neutral 0 mm slot**.
- If **augmentation is needed**, cut through the **+5 mm, +10 mm, or +15 mm slots** on either the **medial** or **lateral side**, independently.
- It is acceptable to have **asymmetric distal augmentation** (e.g., +5 mm medial, +10 mm lateral) based on the pattern of bone loss.

50. Confirm that the distal femoral surface is flat and consistent. Posterior resection and augmentation will be addressed in the next step.

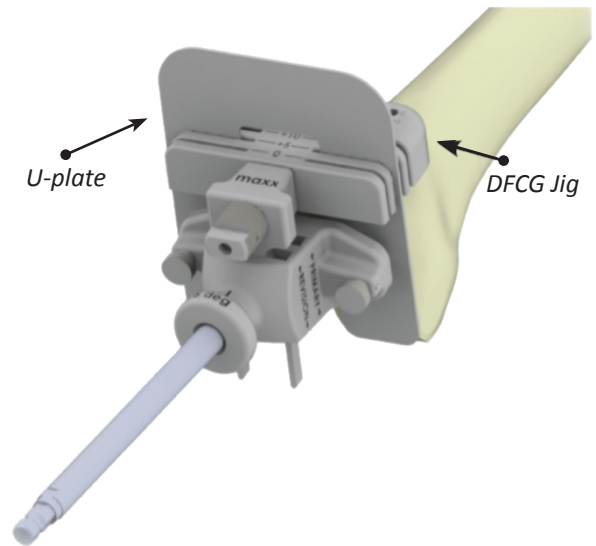

Note:

Femoral distal and posterior augments are optional and intended to address bone deficiencies on the distal and posterior condyles. Each augment is 5 mm thick and designed to be symmetric, allowing correction of medial and lateral defects equally.

- Distal augments may be stacked up to three high (5 mm, 10 mm, or 15 mm total).
- Posterior augments may be stacked up to two high (5 mm or 10 mm total).
- A maximum of four total augments per side is permitted. For example, if three distal augments are used on the medial side, only one posterior augment may be added to that side.

A/P Cutting Block Positioning without Femoral Offset

51. Reinsert the final reamer into the femoral canal and attach the T-handle for stability.

52. Select the appropriate size **femoral A/P** cutting block, ensuring it matches the selected implant size. The medial-lateral width of the block is identical to that of the corresponding PCK femoral component.

53. If **distal augments** were used in the previous step, attach the corresponding augments to the cutting block for proper seating on the resected distal femur.

- Use **small augment footprints** for sizes **B, C, or E**, and **large footprints** for sizes **F, G, or H**.
- Available augment thicknesses: **5 mm, 10 mm, and 15 mm**.
- Use the **augment pin** to secure the augment to the A/P cutting block.

Ensure the appropriate side-specific distal augment (medial or lateral) is selected based on the planned augmentation.

54. Slide the femoral A/P cutting block with its **oblong A/P** insert over the distal reamer. The insert must be oriented correctly with the **arrow pointing toward the surgical laterality** (i.e., “L” for left, “R” for right).

55. Before pinning, insert an **angel wing** through the anterior slot to visualize the anterior cut trajectory and confirm that **notching of the anterior cortex is avoided**.

- If notching is observed or likely, **stop** and proceed to the offset femoral technique.

56. Once the resection plane is confirmed, secure the cutting block to the femur using pins. Use the **side pin holes** on the cutting block for fixation, ensuring firm engagement with bone.

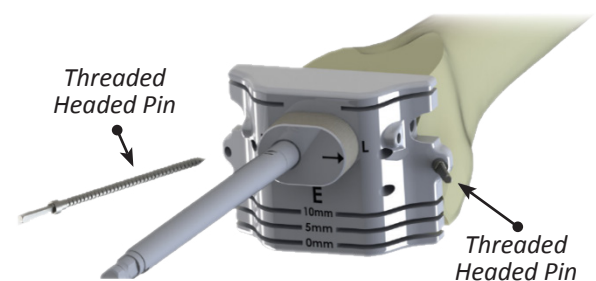
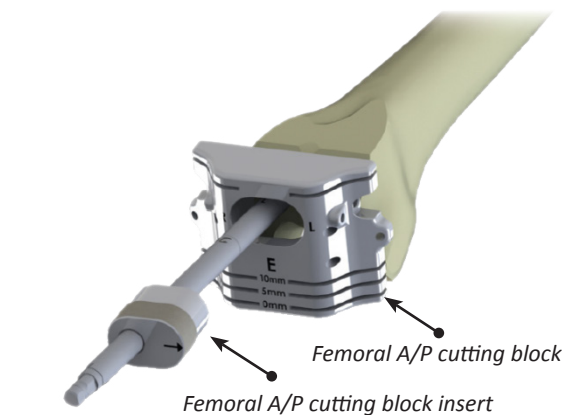
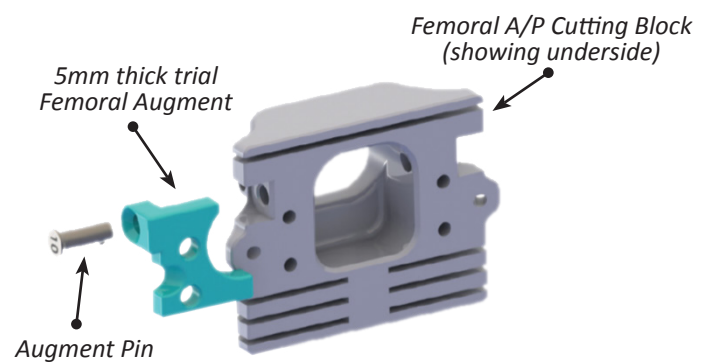

A/P Cutting Block Positioning with Femoral Offset

57. If femoral offsetting is required, first confirm that the distal reamer remains in place in the intramedullary canal. Verify the reaming depth against the **reaming depth** chart (Table A) under the **“With Offset”** column.

- If additional reaming is necessary to match the offset stem extension depth, ream further using the final distal reamer.

58. If **distal augments** were used in the previous step, attach the corresponding augments to the **femoral A/P offsetting block** for proper seating on the resected distal femur.

- Use **small augment footprints** for sizes **B, C, or E**, and **large footprints** for sizes **F, G, or H**.
- Available augment thicknesses: **5 mm, 10 mm, and 15 mm**.
- Use the **augment pin** to secure the augment to the A/P cutting block.

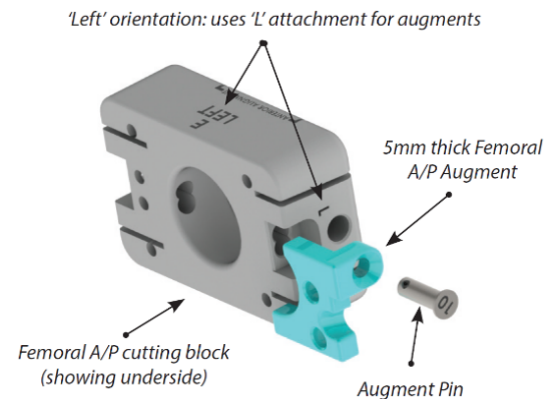

59. Position the **femoral A/P positioning guide** over the distal reamer. Place the **4 mm offset dial**, labeled for the correct operative side (**Left** or **Right**). The offset dial will allow the femoral component to be repositioned in the **anterior/posterior** and **medial/lateral** planes while maintaining the reamer as a central reference.

60. Rotate the offset dial around the reamer to place the guide in the optimal position. Adjust as needed to accommodate:

- Prevention of **anterior notching**
- Centralized **medial/lateral implant positioning**

61. Use an **angel wing** or **L-Plate** through the anterior slot to visualize the planned anterior resection plane. This will define the **final position of the anterior flange** of the femoral PCK implant. Confirm that anterior cortex violation will not occur.

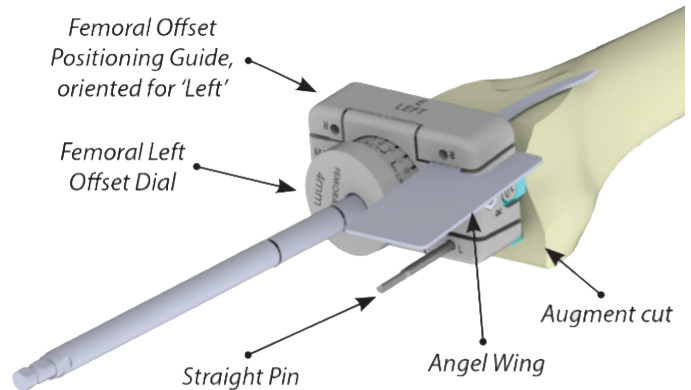

62. Once the desired positioning is achieved, pin the A/P positioning guide to the distal femur.

- Use the designated **“L” or “R” pin holes**, depending on the surgical side.
- Insert **at least two long straight pins** through the three available holes for secure fixation to the resected distal femur.
- Ensure the pins are driven flush with the bone and provide rigid fixation.

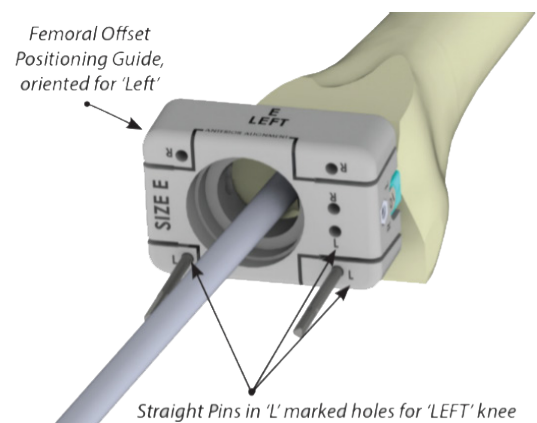

63. Carefully remove the **offset dial** and the **A/P positioning guide**, leaving the **alignment pins** in place. These pins will serve as the reference for final metal block placement.

64. If distal augmentation was prepared, assemble the **metal A/P cutting block** corresponding to the selected implant size .

- If **distal augments** were previously used, attach the **same size and thickness** of augments to the metal cutting block.
- Use the **trial augment pins** to secure the augments to the block, matching both the **footprint** and **thickness** used in prior steps.

– **Small footprints** for sizes **B, C, or E**

– **Large footprints** for sizes **F, G, or H**

– Thicknesses available: **5 mm, 10 mm, 15 mm**

Ensure the appropriate side-specific distal augment (medial or lateral) is selected based on the planned augmentation.

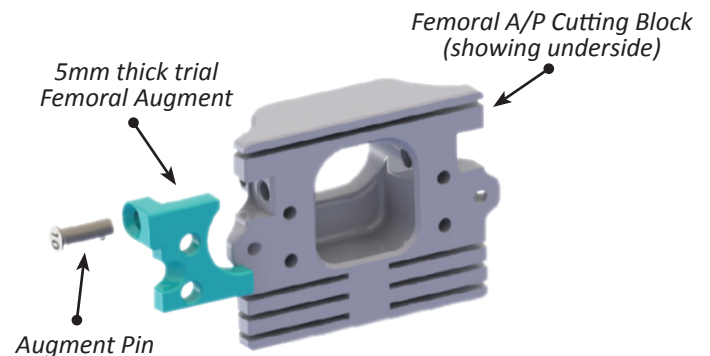

65. Place the metal A/P cutting block onto the bone using the previously placed **long alignment pins** as a guide. Slide it flush against the resected distal surface and over the distal reamer.

66. Reaffirm the anterior resection location using an **angel wing** through the anterior slot. Ensure the anterior flange position does not compromise the femoral cortex.

67. Secure the A/P cutting block using **threaded or long smooth pins** through the **side fixation holes** to maintain cutting block stability.

68. Perform the **anterior and posterior femoral cuts** using an oscillating saw.

- Use the **neutral resection slots** if no posterior augments are required.
- If **posterior augments** are needed, cut through the +5 mm or +10 mm slots accordingly.
- It is acceptable to use **asymmetric posterior augmentation** if required by the bone loss pattern.

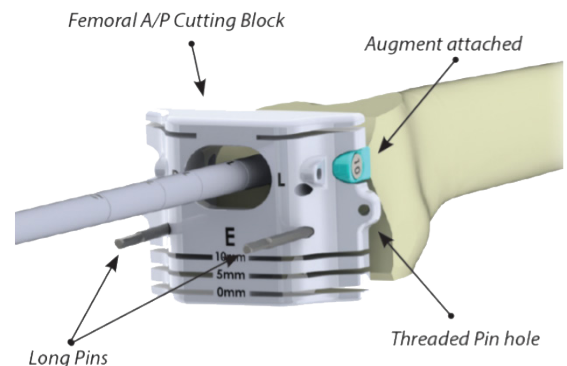

PCK Box Cut Guide & Boss Reaming

- without Femoral Offset

69. Select the appropriate **box cut guide (BCG)** based on the femoral implant size.

- The medial-lateral width of the guide matches the corresponding PCK femoral component.

70. If **distal femoral augments** were used during preparation, attach the corresponding **5 mm, 10 mm, or 15 mm** distal augment to the **distal face** of the BCG to ensure proper seating.

- Ensure orientation is correct to avoid interference with subsequent cuts.

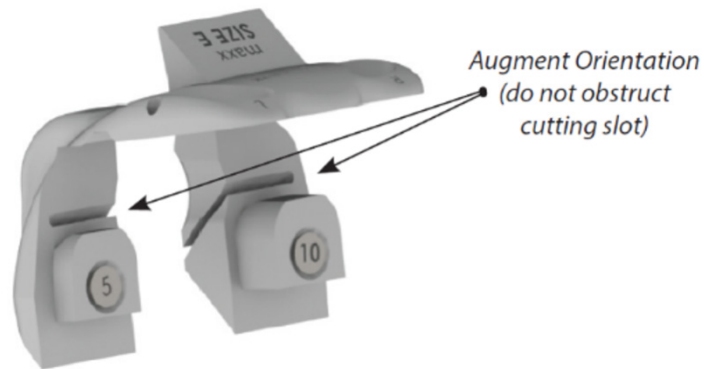

71. Attach the **femoral drill housing** guide to the distal face of the BCG.

- Lay the drill housing across the face of the BCG so that the **screw aligns with the operative side**, and the **alignment peg is placed in the contralateral hole**.
- The printed laterality marking on the housing should be clearly readable, confirming correct orientation.

72. Select the proper **drill housing guide size** based on the implant size:

- **Small housing** for femoral sizes **B, C, or E**
- **Large housing** for femoral sizes **F, G, or H**

73. Insert the **drill guide reducer** into the housing.

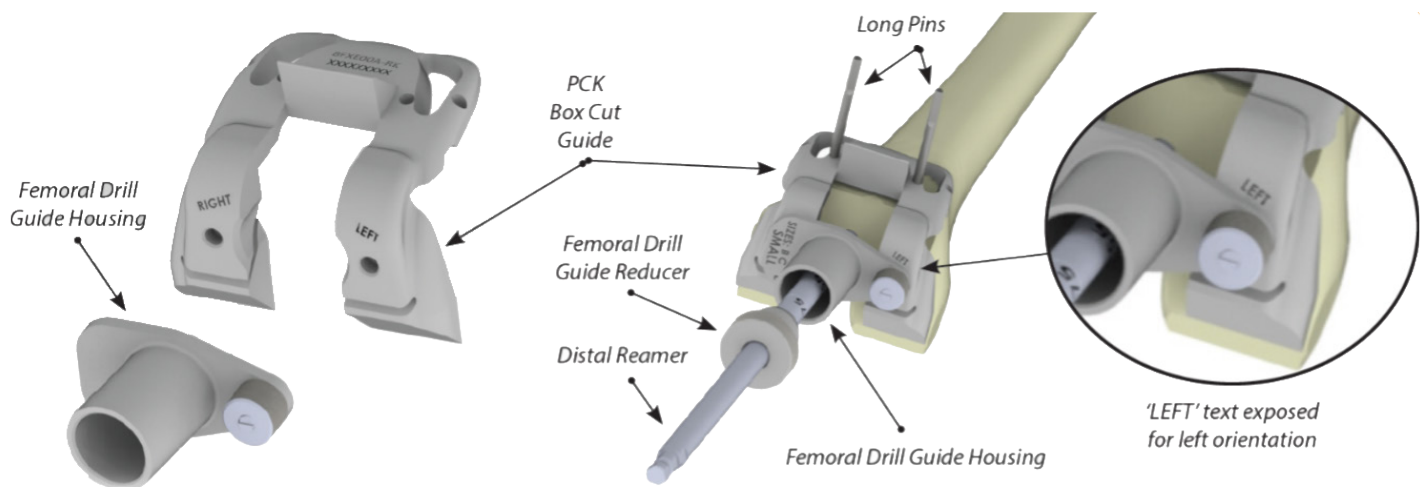

74. Slide the fully constructed box cut guide assembly (BCG + housing + reducer) over the distal reamer, aligning it flush with the distal femur.
75. Secure the BCG to the femur using **two long smooth pins** inserted through the **anterior pin holes**.
76. If the final distal reamer diameter used was **less than 16.5 mm**, remove the **reamer and guide reducer** prior to drilling.
77. Use the **boss reamer** to drill into the distal femur until the **reamer shoulder contacts the top of the housing guide**. This prepares the central boss pocket for the femoral implant.
78. Remove the **housing guide, reducer, and reamer** (if not already removed during drilling).
79. Using a **sagittal saw** and a **double-sided reciprocating blade**, perform the **box and chamfer cuts** through the corresponding cutting slots on the BCG as shown.
- Maintain saw blade control to preserve cortical integrity and avoid undercuts.

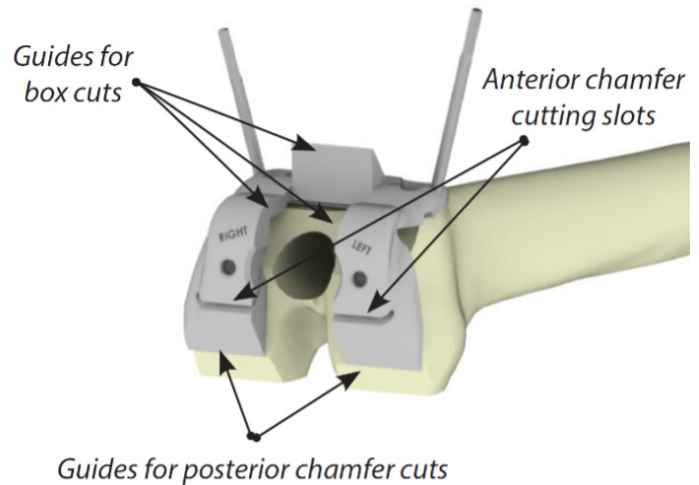
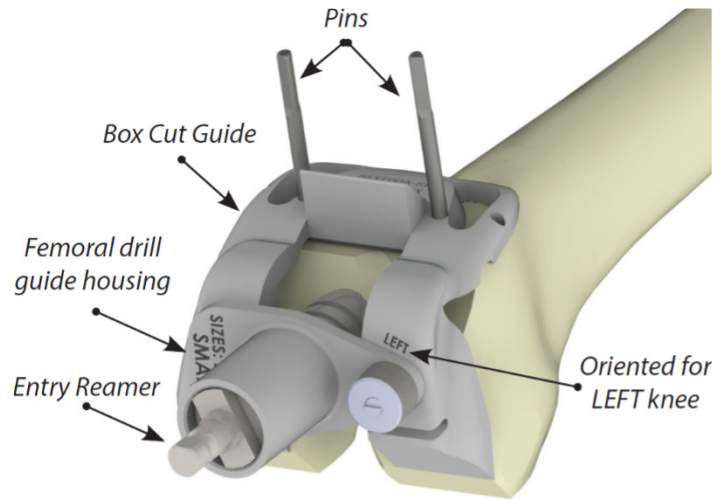

Ensure the appropriate side-specific distal augment (medial or lateral) is selected based on the planned augmentation.

FEMORAL IMPLANT SIZE REAMER Ø	
B	Ø17.5mm
C	Ø18.0mm
E	Ø18.0mm
F	Ø22.0mm
G	Ø22.0mm
H	Ø22.0mm

PCK Box Cut Guide & Boss Reaming

- with Femoral Offset

80. Select and assemble the appropriate **box cut guide (BCG)** that corresponds to the planned implant size.

81. If **distal femoral augments** were used during preparation, attach the corresponding **5 mm, 10 mm, or 15 mm** distal augment to the **distal face** of the BCG to ensure proper seating.

- Use the **trial augment pin** to secure the augment.
- Ensure orientation is correct to avoid interference with subsequent cuts.

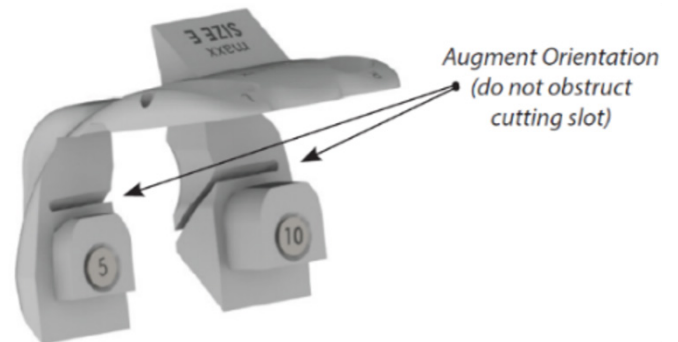

82. Attach the matching **femoral BCG offset plate** to the face of the BCG:

- Use the **small offset plate** for femoral sizes **B–E**
- Use the **large offset plate** for femoral sizes **F–H**
- Ensure the offset plate is oriented according to the **correct operative side**.

83. Position the assembled BCG over the distal reamer and **initially align the guide flush against both the anterior and distal femoral resected surfaces**.

84. Insert the **4 mm offset dial** dependent on laterality over the reamer and seat it into the **recess of the BCG offset plate**.

85. **Rotate the offset dial** around the reamer to fine-tune the position of the BCG in both the **anterior/posterior** and **medial/lateral planes**. Two scenarios may occur:

86. (a) **Optimal Contact:**

The **internal anterior face of the BCG rests fully on the resected anterior femoral cortex**, and medial/lateral coverage is acceptable.

- In this case, proceed. The A/P cutting block positioning was appropriate, and no further modification is needed.

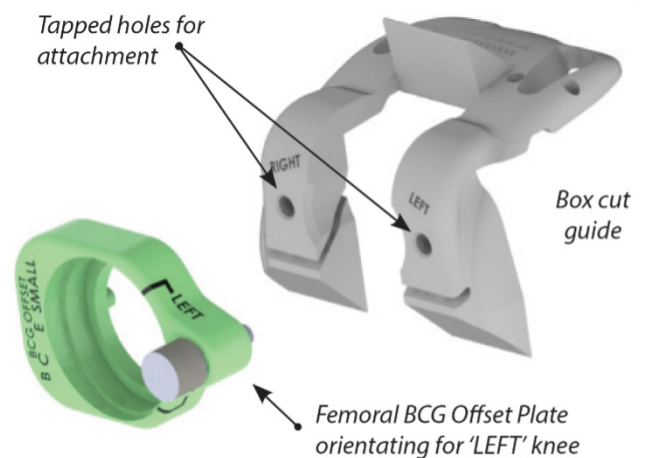

89. 17 mm distal reamer



100 mm depth groove
top surface of the drill
guide housing.



of set junct on and central boss of the femoral implant.

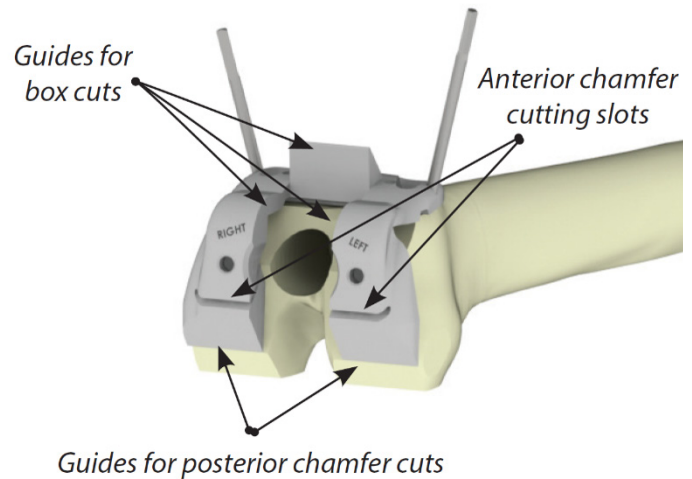

90. Remove the housing guide, reducer, and reamer



Use a sagittal saw and a double-sided reciprocating blade, perform the box and chamfer cuts through the corresponding cutting slots on the BCG.

- Maintain saw blade control to preserve cortical integrity and avoid undercuts

PATELLA PREPARATION

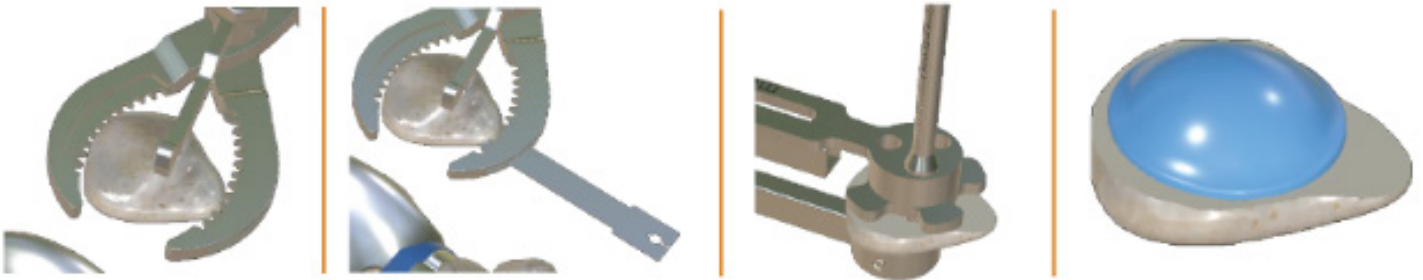

92. Evert the patella

93. Use a caliper

94. Resect patella using either 2 towel clips or patella resection guide.

95. Use the patellar drill guide

96. Drill three holes in the patellar bone using patella drill guide and patella-femoral drill.

97. Place the patella trial

TRIAL ASSEMBLY

Stemmed Tibial Components

98. Select the previously determined tibial tray and stem extension.

99. Determine if tibial offset is required.

No Offset:

– Hand-tighten the stem extension directly into the trial tibial tray keel.

With Offset:

a: Hand-tighten a 4 mm or 6 mm tibial offset adapter into the keel until it spins freely.

b: Align the **letter** on the offset adapter with the **number** on the tibial keel (as identified during preparation).

c: Use a star drive to insert the **15 mm headed screw** from the top of the tray to secure the offset to the tibial baseplate.

d: Hand-tighten the stem extension into the offset adapter.

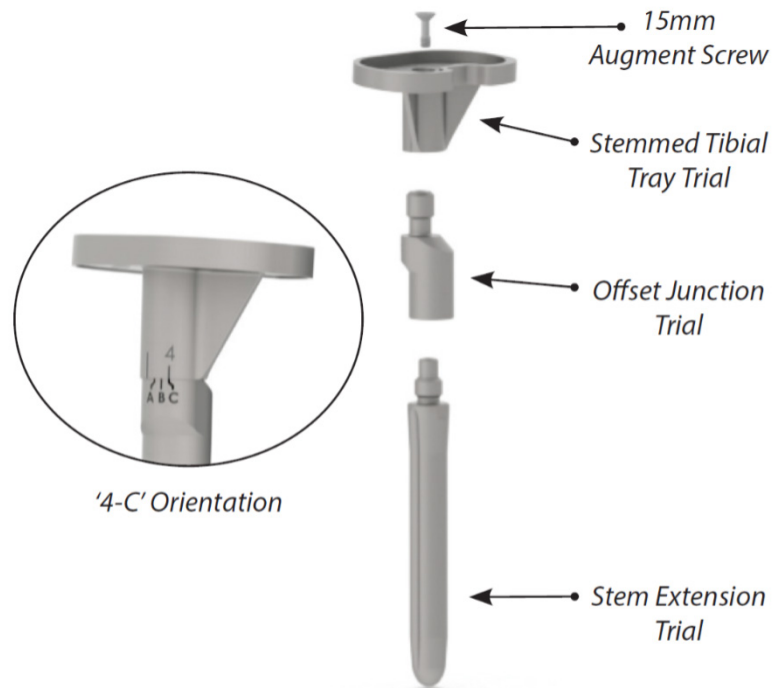

100. If tibial augments are required, select the appropriate sizes and quantities for each medial and lateral compartments as needed.

101. Use a star drive to insert the appropriate **5 mm, 10 mm, or 15 mm headed screws** through the tray into each augment.

102. Augments may be stacked **up to three high per side**, and may be uniform or descending in height.

Femoral Components

103. Select the previously determined femoral component and stem extension.

104. Determine if femoral offset is required.

No Offset:

– Hand-tighten the stem extension directly into the trial femoral component.

With Offset:

a: Hand-tighten the 4 mm offset adapter into the boss of the femoral trial until it spins freely.

b: Align the letter on the offset adapter with the numbered marking on the femoral boss (as determined during preparation).

c: Insert the junction screw into the central hole between the femoral condyles.

d: Use a 2 mm hex driver to fully tighten the junction screw.

e: Hand-tighten the stem extension into the offset adapter.

The black handle screwdriver is torque-limiting.

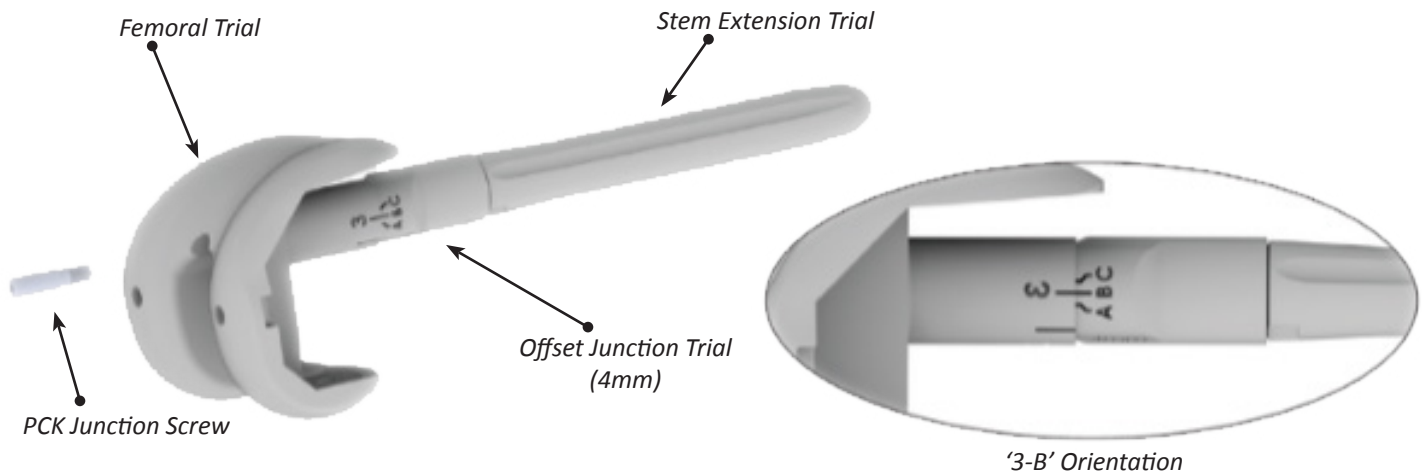

105. Select the appropriate distal and/or posterior femoral augments based on the previously made cuts.

106. Position the augments on the medial and/or lateral sides as required.

107. A maximum of four augments per side is permitted.

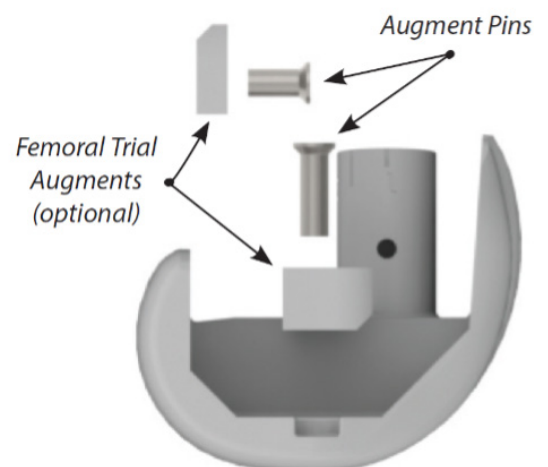

Tibial Insert

108. Select a trial insert with:

- A **top articular surface** matching the femoral size
- A **bottom modular surface** matching the tibial tray size

109. Identify the appropriate insert size and thickness using the labeled configuration (1/2, 3/4, 5/6, 7/8), ranging from **11, 14, 17, 20, 23, 27, 31mm**.

110. Insert the trial between the assembled femoral and tibial constructs.

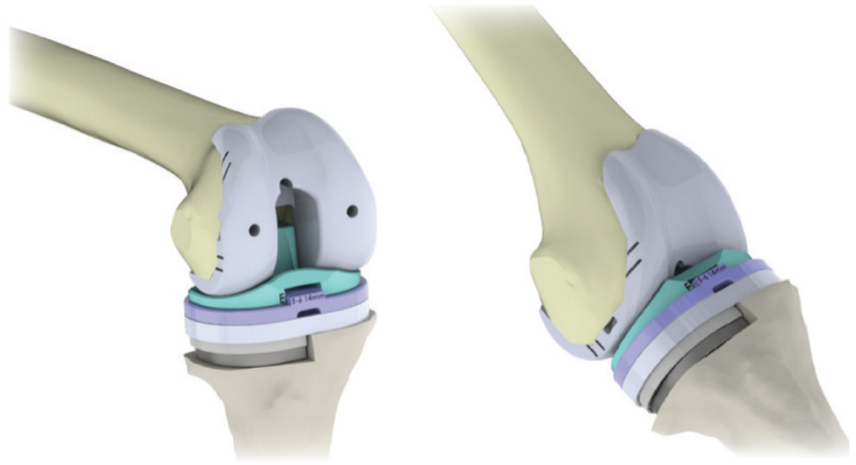

TRIAL REDUCTION & GAP BALANCING

111. Perform a **comprehensive trial reduction**, fully seating all components and assessing the following:

112. If imbalances exist, make intraoperative adjustments:

- Consider using a **thicker or thinner tibial insert** to adjust joint space.
- Adjust femoral or tibial augments if the imbalance is due to asymmetric bony preparation.
- Perform **targeted soft tissue releases** to address ligamentous imbalance in either flexion or extension.
- Re-check joint kinematics after each adjustment.

113. Once optimal stability, tracking, and motion are confirmed, remove the trial components:

- Remove the **femoral trial** and **offset junction**
- Remove the **tibial trial assembly**, including any augments and stem

114. Document the following before proceeding to final implantation:

- Femoral component size**
- Femoral stem size**
- Posterior/distal augment size(s), if used**
- Femoral stem offset and alignment marking**
- Tibial tray size**
- Tibial stem size**
- Augment configuration**
- Tibial stem offset and alignment marking**
- Trial insert size and thickness**
- Patellar size**

FINAL ASSEMBLY & IMPLANTATION

Final Implantation: Stemmed Tibial Assembly

115. Remove the **keel plug** using a Kocher.

116. Unscrew the **center plug** on top of the tibial tray using a **2 mm hex driver**.

– Note: Set screws are provided in a small, separate pouch within the tibial tray packaging.

For Stem (no offset):

117. Attach the **stem** directly to the tibial baseplate.

118. If the stem is **slotted**, orient the **splines in the A/P direction**.

119. Place a towel or lap sponge over the end of the stem and **mallet the Morse-taper junction** together until fully seated.

120. If the **set screw** is not pre-loaded in the keel, retrieve it from the small pouch and insert it.

121. Use the **2 mm hex driver** to **tighten the set screw** into the stem.

For Offset Stem:

122. Place the Morse-taper offset junction into the tibial keel, referencing the orientation used during trialing.

123. Place a towel or lap on the end and **mallet the offset junction into the keel**.

124. Insert and **tighten the keel set screw** using the 2 mm hex.

125. Insert the **Morse-taper of the stem** into the offset junction.

126. If the stem is **slotted**, orient the **splines A/P**.

127. Mallet the stem into the offset junction using a towel or lap.

128. Use the **2 mm hex** to insert and **tighten the set screw** into the offset junction.

For Augments:

129. Place the tibial tray **face down** on a towel.

130. Use a **2 mm hex driver** to remove the **plug(s)** on the distal side corresponding to the augment location.

131. Attach the augment to the tray and insert the **appropriate length screw** from the **top of the tray**, threading into the augment.

– Only **one augment should be attached at a time** to ensure proper screw engagement.

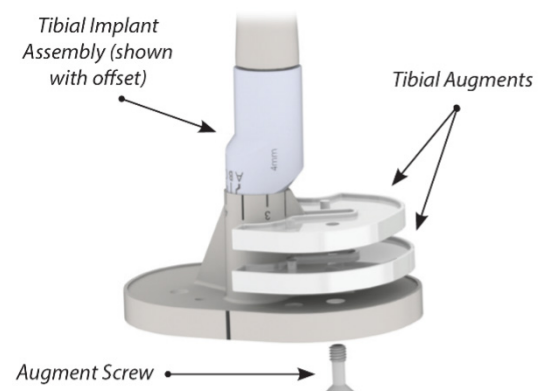
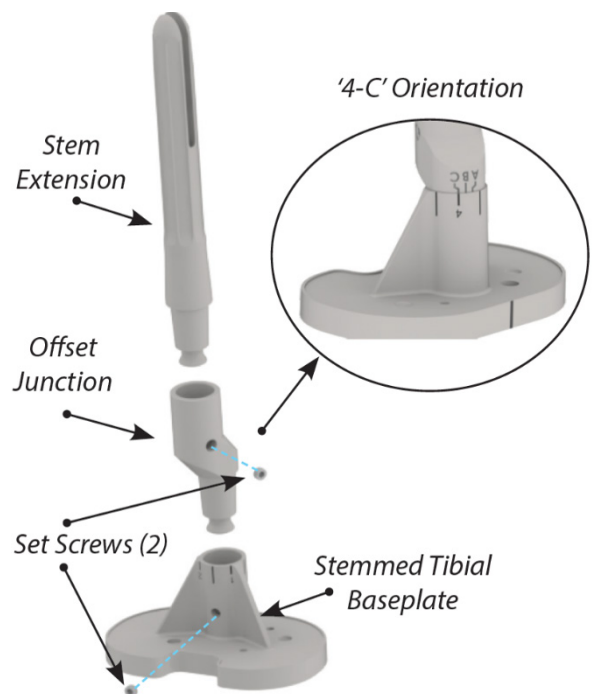

Tibial Stem Fixation – Cemented or Press-Fit

General Tibial Preparation

132. Pulse lavage the tibial canal and metaphyseal bone to remove debris, blood, and fat.
133. Dry the canal and proximal tibial surface thoroughly with sterile sponges or suction.
134. Place a canal plug if cementing to allow for retrograde pressurization and to prevent cement over-extrusion.
135. Inspect the tibial baseplate, stem, offset junction (if applicable), and distal augments to confirm all components are clean and ready for implantation.

Cemented Tibial Stem Technique

136. Load low- or medium-viscosity cement into a cement gun.
137. Insert cement retrograde into the tibial canal, slowly withdrawing the nozzle to fill the canal evenly.
138. Apply cement to the underside of the baseplate, around the keel, stem interface, and inside any augment pockets if used.
139. Insert the tibial construct (stem, offset, augments, tray) as a single unit.
 - If using an offset junction, pre-assemble and align based on trialing.
 - Ensure Morse taper junctions are fully seated prior to implantation.
140. Impact the component into position using controlled mallet force and the tibial impactor.
141. Maintain axial pressure until cement begins to polymerize.
142. Remove excess cement from around the tray edges, stem base, and posterior border before it hardens.

Press-Fit Tibial Stem Technique

143. Ensure canal was reamed to match stem diameter.
 - No canal plug is needed.
144. Do not apply cement to the canal or stem. Optionally, place a small cement mantle on the baseplate underside only (hybrid fixation).
145. Align and insert the tibial construct with a firm, axial push.
 - Confirm orientation of offset (if used) and spline alignment (if slotted stem).
146. Impact the construct to final seating using a mallet and lap pad.
147. Verify rotational alignment and stability. No movement should be present.

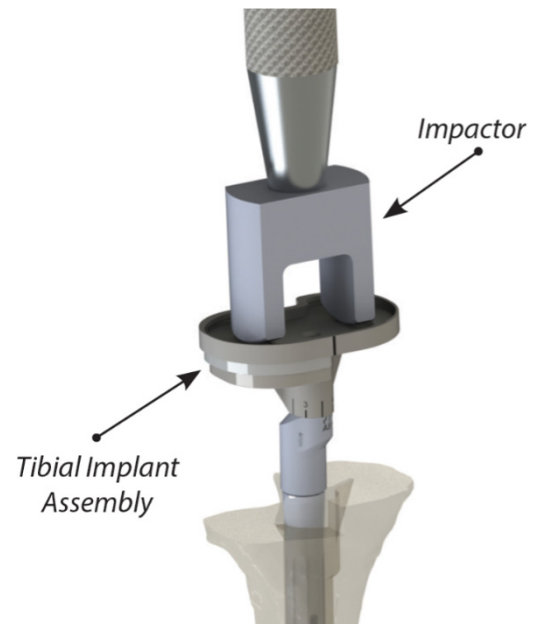

Final Implantation: Femoral Assembly

148. Remove the **plug** from the femoral boss, if present.

– Note: Femoral set screws are included in a small separate pouch within the femoral packaging.

For Stem (no offset):

149. Attach the stem directly to the femoral boss.

150. If the stem is **slotted**, orient the **splines M/L**.

151. Place a towel or lap on the end and **mallet the Morse-taper stem** into the boss until fully engaged.

152. Insert the **set screw** into the boss and **tighten using a 2 mm hex**.

For Offset:

153. Place the **Morse-taper offset junction** into the femoral boss (referencing trial orientation).

154. Mallet into place using a towel or lap on the end.

155. Insert and **tighten the boss set screw** using a 2 mm hex driver.

156. Insert the **stem** into the offset junction.

157. If slotted, orient **splines M/L**.

158. Mallet together using a towel or lap.

159. Insert and **tighten the set screw** into the offset junction using a 2 mm hex.

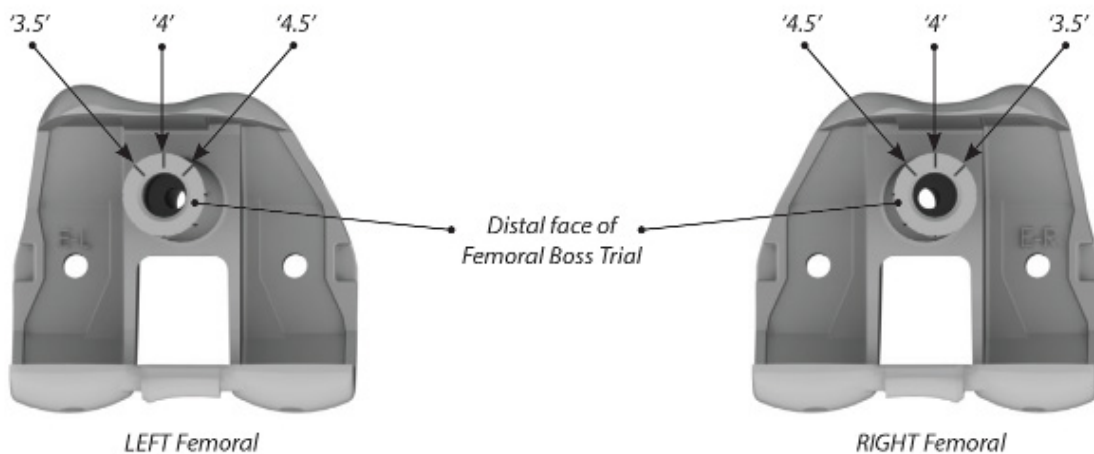
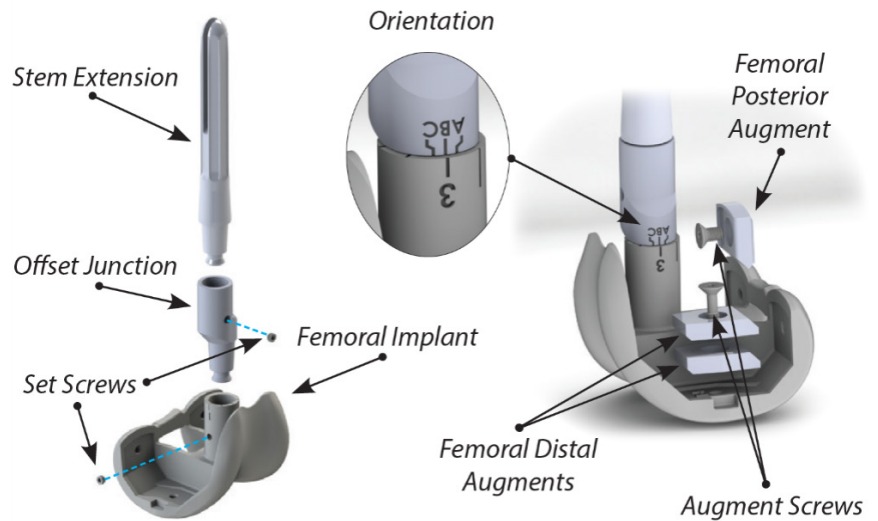

Markings for aligning the Offset Junction

For Augments:

160. Attach **posterior and/or distal augments** using the appropriate **screw lengths** based on resection depth.

161. Always attach **smaller augments before stacking larger ones** for a secure interface.

162. Ensure **posterior and distal augments** are placed correctly—each has a distinct shape and location.

Femoral Stem Fixation – Cemented or Press-Fit

General Femoral Preparation

163. Pulse lavage the femoral canal and bone cuts, including box and condyles.
164. Dry the canal and internal femoral bone surfaces with suction and sterile gauze.
165. Place a canal plug if cementing, positioned just distal to the intended stem length.
166. Inspect femoral component, stem, offset junction, and augments for proper assembly and cleanliness.

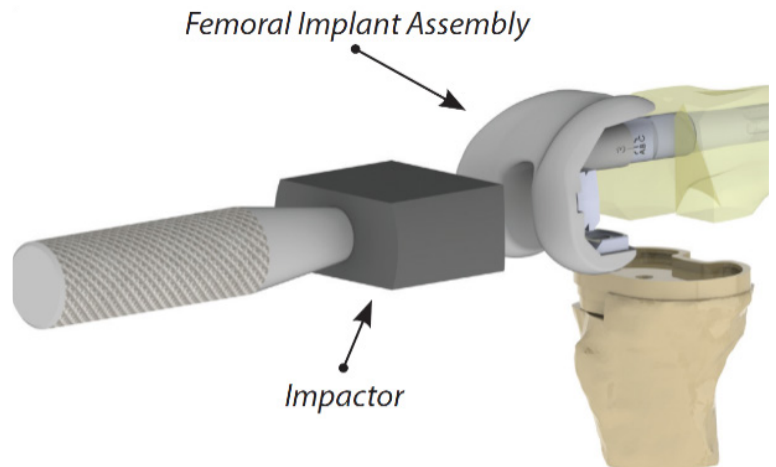

Cemented Femoral Stem Technique

167. Use a cement gun to inject cement **retrograde into the femoral canal**, withdrawing slowly to fill.
168. Apply cement to the **internal box, distal condyles, and augment pockets**, ensuring full surface coverage.
169. If using offset, insert and fully seat the Morse taper **offset adapter into the boss** prior to cementing.
170. Assemble the full femoral construct (including offset and stem if applicable) and insert in a single motion.
171. Impact the component using controlled force to seat the femoral implant fully.
172. Hold axial pressure until the cement sets. Ensure the anterior flange and posterior condyles contact the bone surface evenly.
173. Remove any excess cement from around the box, chamfers, and trochlear region before it hardens.

Press-Fit Femoral Stem Technique

174. Confirm that the canal was reamed to the **same diameter as the stem**.
175. Do **not cement the stem** or canal. Optionally apply cement to the femoral box and condyles only (hybrid fixation).
176. If using offset, seat the Morse taper junctions prior to insertion and align rotationally as trialed.
177. Insert the femoral component with a single, axial motion.
 - Orient slotted stems **M/L** if applicable.
178. Impact into final position with firm mallet strikes.
179. Verify full seating of the component and confirm that it is rotationally stable.

Final Implantation: Poly Insert

- 180. Retrieve the insert and the **locking screw** (included pre-assembled within the poly insert).
- 181. Insert the poly at a **45° angle**, seating the **posterior edge first** into the tibial tray.
- 182. Impact tibial insert into the tibial tray utilizing the tibial impactor.
- 183. Use a **2 mm hex driver** to insert and **tighten the locking screw** into the tibial tray from above to secure the insert.

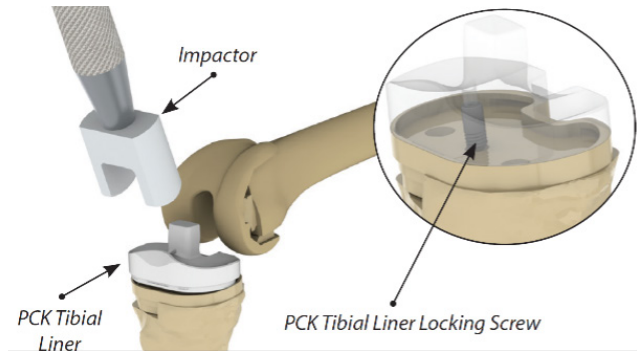

Final Implantation: Patella

- 184. Place knee into extension.
- 185. Evert the patella and dry the bony surface of the patella.
- 186. Place cement into the patella bone surface.
- 187. Apply bone cement to the undersurface of the patella implant.
- 188. Place the patella implant in the resected bone.
- 189. Trim excess osteophytes.
- 190. Remove excess cement.

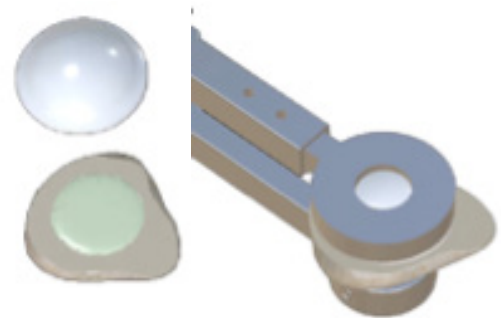

Incision Closure

- 191. The incision is closed in layers. Take care that all excess cement has been removed prior to closure.

FREEDOM® PCK® Revision Knee System

Ordering Information

SET #	DESCRIPTION
INS-PCK1-A	Freedom PCK Case A - PCK Femoral Instruments
INS-PCK1-B	Freedom PCK Case B - PCK Insert & Femoral Trials
INS-PCK1-1	Freedom PCK Case 1 - PCK Stem Tibia Instruments
INS-PCK1-2	Freedom PCK Case 2 - Stem Reamers & Trials
INS-PCK1-3	Freedom PCK Case 3 - Additional Stem Reamers & Trials
INS-PCK1-APK	Freedom PCK Case APK - Additional Primary Knee Instruments

FREEDOM PCK CASE A PCK

FEMORAL INSTRUMENTS - TOP

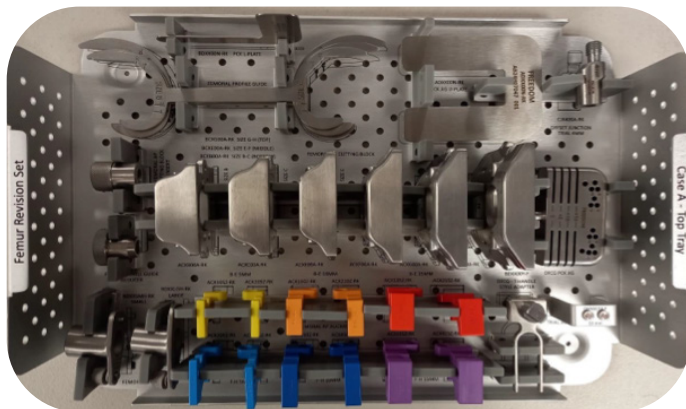

FREEDOM PCK CASE A PCK

FEMORAL INSTRUMENTS - BOTTOM

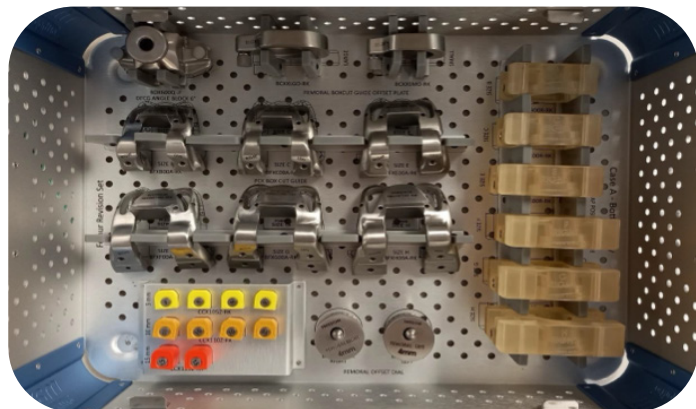

PART #	DESCRIPTION	QTY
BCXB00A-RK	FEMORAL PROFILE GUIDE, SIZE B-C	1
BCXE00A-RK	FEMORAL PROFILE GUIDE, SIZE E-F	1
BCXG00A-RK	FEMORAL PROFILE GUIDE, SIZE G-H	1
ADXX00N-RK	PCK JIG U-PLATE	1
BDXX00N-RK	PCK JIG L-PLATE	1
CJX400A-RK	OFFSET JUNCTION TRIAL 4MM	1
ACXX00N-RK	FEMORAL AP CUTTING BLOCK INSERT	1
BDXX09Y-RK	FEMORAL DRILL GUIDE REDUCER	1
ACXB00A-RK	FEMORAL AP CUTTING BLOCK, SIZE B	1
ACXC00A-RK	FEMORAL AP CUTTING BLOCK, SIZE C	1
ACXE00A-RK	FEMORAL AP CUTTING BLOCK, SIZE E	1
ACXF00A-RK	FEMORAL AP CUTTING BLOCK, SIZE F	1
ACXG00A-RK	FEMORAL AP CUTTING BLOCK, SIZE G	1
ACXH00A-RK	FEMORAL AP CUTTING BLOCK, SIZE H	1
ADXX00W-RK	DFCG PCK JIG	1
BDXXSMH-RK	FEMORAL DRILL GUIDE, SMALL	1
BDXXLGH-RK	FEMORAL DRILL GUIDE, LARGE	1
ACX105Z-RK	FEMORAL AP AUGMENT, B-E 5MM	1
ACX205Z-RK	FEMORAL AP AUGMENT, B-E 5MM	1
ACX110Z-RK	FEMORAL AP AUGMENT, B-E 10MM	1
ACX210Z-RK	FEMORAL AP AUGMENT, B-E 10MM	1
ACX115Z-RK	FEMORAL AP AUGMENT, B-E 15MM	1
ACX215Z-RK	FEMORAL AP AUGMENT, B-E 15MM	1
ACX305Z-RK	FEMORAL AP AUGMENT, F-H 5MM	1
ACX405Z-RK	FEMORAL AP AUGMENT, F-H 5MM	1
ACX310Z-RK	FEMORAL AP AUGMENT, F-H 10MM	1
ACX410Z-RK	FEMORAL AP AUGMENT, F-H 10MM	1
ACX315Z-RK	FEMORAL AP AUGMENT, F-H 15MM	1
ACX415Z-RK	FEMORAL AP AUGMENT, F-H 15MM	1
BDXX00Y-F	DFCG - T-HANDLE STYLE ADAPTER	1
DMXX15A-F	TRIAL AUGMENT PIN, 10MM	2

PART #	DESCRIPTION	QTY
BDX600Q-RK	DFCG ANGLE BLOCK 6 DEGREE	1
BCXXSMO-RK	FEMORAL BOXCUT GUIDE OFFSET PLATE SMALL	1
BCXXLGO-RK	FEMORAL BOXCUT GUIDE OFFSET PLATE LARGE	1
BFXB00A-RK	PCK BOX CUT GUIDE, SIZE B	1
BFXC00A-RK	PCK BOX CUT GUIDE, SIZE C	1
BFXE00A-RK	PCK BOX CUT GUIDE, SIZE E	1
BFXF00A-RK	PCK BOX CUT GUIDE, SIZE F	1
BFXG00A-RK	PCK BOX CUT GUIDE, SIZE G	1
BFXH00A-RK	PCK BOX CUT GUIDE, SIZE H	1
CCX105Z-RK	FEMORAL AUGMENT TRIAL, 5MM	4
CCX110Z-RK	FEMORAL AUGMENT TRIAL, 10MM	4
CCX115Z-RK	FEMORAL AUGMENT TRIAL, 15MM	2
DMXX10A-F	TRIAL AUGMENT PIN, 5MM	4
DMXX15A-F	TRIAL AUGMENT PIN, 10MM	4
DMXX20A-F	TRIAL AUGMENT PIN, 15MM	2
BCRX04O-RK	FEMORAL OFFSET DIAL RIGHT	1
BCLX04O-RK	FEMORAL OFFSET DIAL LEFT	1
ACXB00R-RK	FEMORAL AP POSITIONING GUIDE, SIZE B	1
ACXC00R-RK	FEMORAL AP POSITIONING GUIDE, SIZE C	1
ACXE00R-RK	FEMORAL AP POSITIONING GUIDE, SIZE E	1
ACXF00R-RK	FEMORAL AP POSITIONING GUIDE, SIZE F	1
ACXG00R-RK	FEMORAL AP POSITIONING GUIDE, SIZE G	1
ACXH00R-RK	FEMORAL AP POSITIONING GUIDE, SIZE H	1

FREEDOM PCK CASE B PCK

PCK INSERT & FEMORAL TRIALS - TOP



FREEDOM PCK CASE B PCK

PCK INSERT & FEMORAL TRIALS - BOTTOM

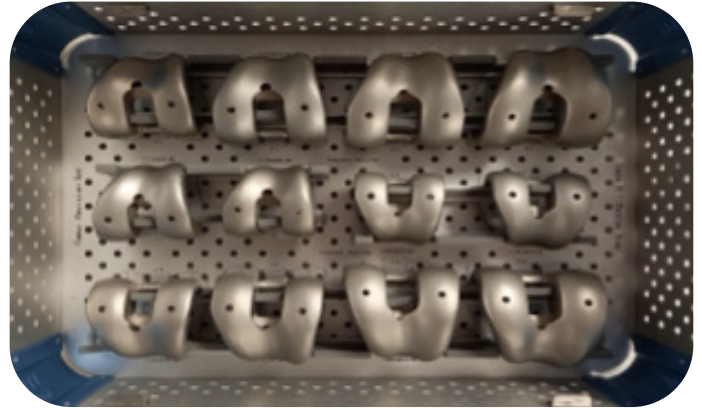

PART #	DESCRIPTION	QTY
CBX111A-F	TIBIAL TRIAL INSERT BOTTOM SIZE 1-2, 11mm	1
CBX114A-F	TIBIAL TRIAL INSERT BOTTOM SIZE 1-2, 14mm	1
CBX117A-F	TIBIAL TRIAL INSERT BOTTOM SIZE 1-2, 17mm	1
CBX120A-F	TIBIAL TRIAL INSERT BOTTOM SIZE 1-2, 20mm	1
CBX123A-F	TIBIAL TRIAL INSERT BOTTOM SIZE 1-2, 23mm	1
CBX127A-F	TIBIAL TRIAL INSERT BOTTOM SIZE 1-2, 27mm	1
CBX131A-F	TIBIAL TRIAL INSERT BOTTOM SIZE 1-2, 31mm	1
CBX311A-F	TIBIAL TRIAL INSERT BOTTOM SIZE 3-4, 11mm	1
CBX314A-F	TIBIAL TRIAL INSERT BOTTOM SIZE 3-4, 14mm	1
CBX317A-F	TIBIAL TRIAL INSERT BOTTOM SIZE 3-4, 17mm	1
CBX320A-F	TIBIAL TRIAL INSERT BOTTOM SIZE 3-4, 20mm	1
CBX323A-F	TIBIAL TRIAL INSERT BOTTOM SIZE 3-4, 23mm	1
CBX327A-F	TIBIAL TRIAL INSERT BOTTOM SIZE 3-4, 27mm	1
CBX331A-F	TIBIAL TRIAL INSERT BOTTOM SIZE 3-4, 31mm	1
CBX511A-F	TIBIAL TRIAL INSERT BOTTOM SIZE 5-6, 11mm	1
CBX514A-F	TIBIAL TRIAL INSERT BOTTOM SIZE 5-6, 14mm	1
CBX517A-F	TIBIAL TRIAL INSERT BOTTOM SIZE 5-6, 17mm	1
CBX520A-F	TIBIAL TRIAL INSERT BOTTOM SIZE 5-6, 20mm	1
CBX523A-F	TIBIAL TRIAL INSERT BOTTOM SIZE 5-6, 23mm	1
CBX527A-F	TIBIAL TRIAL INSERT BOTTOM SIZE 5-6, 27mm	1
CBX531A-F	TIBIAL TRIAL INSERT BOTTOM SIZE 5-6, 31mm	1
CBX711A-F	TIBIAL TRIAL INSERT BOTTOM SIZE 7-8, 11mm	1
CBX714A-F	TIBIAL TRIAL INSERT BOTTOM SIZE 7-8, 14mm	1
CBX717A-F	TIBIAL TRIAL INSERT BOTTOM SIZE 7-8, 17mm	1
CBX720A-F	TIBIAL TRIAL INSERT BOTTOM SIZE 7-8, 20mm	1
CBX723A-F	TIBIAL TRIAL INSERT BOTTOM SIZE 7-8, 23mm	1
CBX727A-F	TIBIAL TRIAL INSERT BOTTOM SIZE 7-8, 27mm	1
CBX731A-F	TIBIAL TRIAL INSERT BOTTOM SIZE 7-8, 31mm	1
CBXB00RK-RK	TIBIAL TRIAL INSERT TOP SIZE B PCK	1
CBXC00RK-RK	TIBIAL TRIAL INSERT TOP SIZE C PCK	1
CBXE00RK-RK	TIBIAL TRIAL INSERT TOP SIZE E PCK	1
CBXF00RK-RK	TIBIAL TRIAL INSERT TOP SIZE F PCK	1
CBXG00RK-RK	TIBIAL TRIAL INSERT TOP SIZE G PCK	1
CBXH00RK-RK	TIBIAL TRIAL INSERT TOP SIZE H PCK	1

PART #	DESCRIPTION	QTY
CCLB00PS-RK	PCK FEMORAL TRIAL, SIZE B, LEFT	1
CCLC00PS-RK	PCK FEMORAL TRIAL, SIZE C, LEFT	1
CCLE00PS-RK	PCK FEMORAL TRIAL, SIZE E, LEFT	1
CCLF00PS-RK	PCK FEMORAL TRIAL, SIZE F, LEFT	1
CCLG00PS-RK	PCK FEMORAL TRIAL, SIZE G, LEFT	1
CCLH00PS-RK	PCK FEMORAL TRIAL, SIZE H, LEFT	1
CCRB00PS-RK	PCK FEMORAL TRIAL, SIZE B, RIGHT	1
CCRC00PS-RK	PCK FEMORAL TRIAL, SIZE C, RIGHT	1
CCRE00PS-RK	PCK FEMORAL TRIAL, SIZE E, RIGHT	1
CCRF00PS-RK	PCK FEMORAL TRIAL, SIZE F, RIGHT	1
CCRG00PS-RK	PCK FEMORAL TRIAL, SIZE G, RIGHT	1
CCRH00PS-RK	PCK FEMORAL TRIAL, SIZE H, RIGHT	1

FREEDOM PCK CASE 1

PCK STEM TIBIAL INSTRUMENTS - TOP

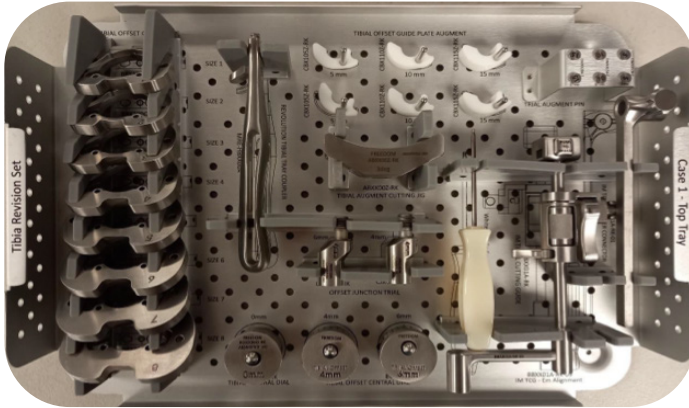

FREEDOM PCK CASE 1

PCK STEM TIBIAL INSTRUMENTS - BOTTOM

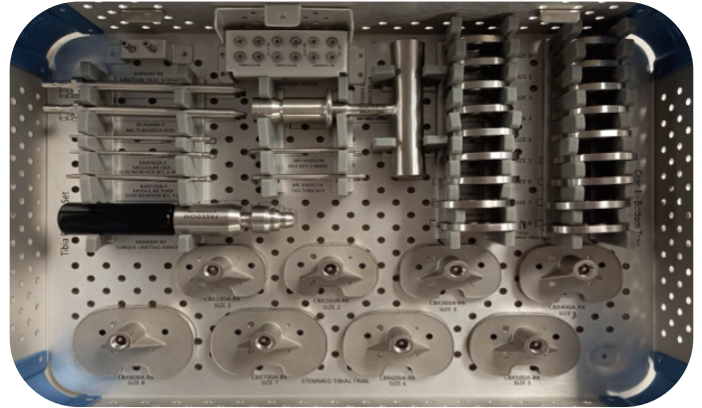

PART #	DESCRIPTION	QTY
BBX1000-RK	TIBIAL OFFSET GUIDE PLATE SIZE 1	1
BBX2000-RK	TIBIAL OFFSET GUIDE PLATE SIZE 2	1
BBX3000-RK	TIBIAL OFFSET GUIDE PLATE SIZE 3	1
BBX4000-RK	TIBIAL OFFSET GUIDE PLATE SIZE 4	1
BBX5000-RK	TIBIAL OFFSET GUIDE PLATE SIZE 5	1
BBX6000-RK	TIBIAL OFFSET GUIDE PLATE SIZE 6	1
BBX7000-RK	TIBIAL OFFSET GUIDE PLATE SIZE 7	1
BBX8000-RK	TIBIAL OFFSET GUIDE PLATE SIZE 8	1
MF-HBX00A	TIBIAL TRAY COUPLER	1
CBX105Z-RK	TIBIAL OFFSET GUIDE PLATE AUGMENT, 5MM	2
CBX110Z-RK	TIBIAL OFFSET GUIDE PLATE AUGMENT, 10MM	2
CBX115Z-RK	TIBIAL OFFSET GUIDE PLATE AUGMENT, 15MM	2
DMXX10A-F	TRIAL AUGMENT PIN, 5MM	2
DMXX15A-F	TRIAL AUGMENT PIN, 10MM	2
DMXX20A-F	TRIAL AUGMENT PIN, 15MM	2
ABXX00Z-RK	TIBIAL AUGMENT CUTTING JIG	1
CJX600A-RK	OFFSET JUNCTION TRIAL 6MM	1
CJX400A-RK	OFFSET JUNCTION TRIAL 4MM	1
BOXX000-RK	TIBIAL OFFSET CENTRAL DIAL, 0MM	1
BOXX040-RK	TIBIAL OFFSET CENTRAL DIAL, 4MM	1
BOXX060-RK	TIBIAL OFFSET CENTRAL DIAL, 6MM	1
11821	WHITE HANDLE HEX SCREWDRIVER 2.0MM	1
BBXX01A-RK	IM TIBIAL CUTTING GUIDE	1
BBXX01A-RK-01	IM TCG - REAMER CONNECTOR	1
BBXX01A-RK	IM TCG - EM ALIGNMENT	1

PART #	DESCRIPTION	QTY
JHXX04F-RK	JUNCTION TRIAL SCREW	2
CMXX07U-RK	TRIAL AUGMENT SCREW, SIZE 7MM	4
CMXX12U-RK	TRIAL AUGMENT SCREW, SIZE 12MM	4
CMXX17U-RK	TRIAL AUGMENT SCREW, SIZE 17MM	4
DCXM04F-F	M6/M4 THREADED ROD	2
KAXH02A-F	MODULAR HEX SCREWDRIVER BIT 2.0MM	2
KAXT15A-F	MODULAR TORX SCREWDRIVER BIT, T15	1
KAXX00K-RK	TORQUE LIMITING HANDLE	1
MF-MXO-00085	T-HANDLE	1
MF-KAXX20K	HEX KEY 2.0MM	2
MF-KAXX15K	T15 TORX KEY	1
CTX000A-RK	TIBIAL AUGMENT TRIAL, SIZE 0	2
CTX100A-RK	TIBIAL AUGMENT TRIAL, SIZE 1	2
CTX200A-RK	TIBIAL AUGMENT TRIAL, SIZE 2	2
CTX300A-RK	TIBIAL AUGMENT TRIAL, SIZE 3	2
CTX400A-RK	TIBIAL AUGMENT TRIAL, SIZE 4	2
CTX500A-RK	TIBIAL AUGMENT TRIAL, SIZE 5	2
CTX600A-RK	TIBIAL AUGMENT TRIAL, SIZE 6	2
CTX700A-RK	TIBIAL AUGMENT TRIAL, SIZE 7	2
CTX800A-RK	TIBIAL AUGMENT TRIAL, SIZE 8	2
CBX100A-RK	STEMMED TIBIAL TRIAL, SIZE 1	1
CBX200A-RK	STEMMED TIBIAL TRIAL, SIZE 2	1
CBX300A-RK	STEMMED TIBIAL TRIAL, SIZE 3	1
CBX400A-RK	STEMMED TIBIAL TRIAL, SIZE 4	1
CBX500A-RK	STEMMED TIBIAL TRIAL, SIZE 5	1
CBX600A-RK	STEMMED TIBIAL TRIAL, SIZE 6	1
CBX700A-RK	STEMMED TIBIAL TRIAL, SIZE 7	1
CBX800A-RK	STEMMED TIBIAL TRIAL, SIZE 8	1

FREEDOM PCK CASE 3

STEM REAMERS & TRIALS - TOP

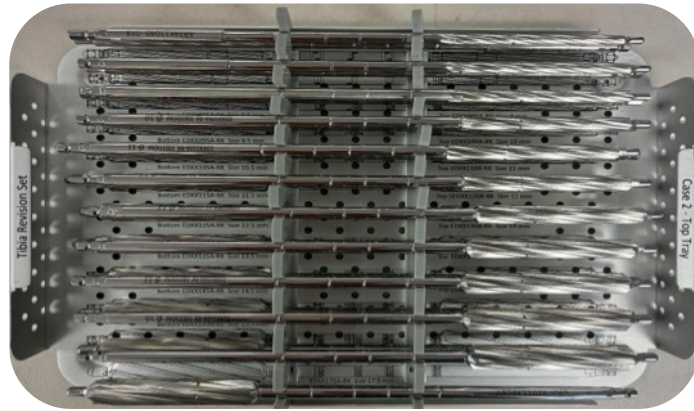

PART #	DESCRIPTION	QTY
EDXX065A-RK	DISTAL REAMER 6.5MM	1
EDXX070A-RK	DISTAL REAMER 7MM	1
EDXX075A-RK	DISTAL REAMER 7.5MM	1
EDXX080A-RK	DISTAL REAMER 8MM	1
EDXX085A-RK	DISTAL REAMER 8.5MM	1
EDXX090A-RK	DISTAL REAMER 9MM	1
EDXX095A-RK	DISTAL REAMER 9.5MM	1
EDXX100A-RK	DISTAL REAMER 10MM	1
EDXX105A-RK	DISTAL REAMER 10.5MM	1
EDXX110A-RK	DISTAL REAMER 11MM	1
EDXX115A-RK	DISTAL REAMER 11.5MM	1
EDXX120A-RK	DISTAL REAMER 12MM	1
EDXX125A-RK	DISTAL REAMER 12.5MM	1
EDXX130A-RK	DISTAL REAMER 13MM	1
EDXX135A-RK	DISTAL REAMER 13.5MM	1
EDXX140A-RK	DISTAL REAMER 14MM	1
EDXX145A-RK	DISTAL REAMER 14.5MM	1
EDXX150A-RK	DISTAL REAMER 15MM	1
EDXX155A-RK	DISTAL REAMER 15.5MM	1
EDXX160A-RK	DISTAL REAMER 16MM	1
EDXX165A-RK	DISTAL REAMER 16.5MM	1
EDXX170A-RK	DISTAL REAMER 17MM	1
EDXX175A-RK	DISTAL REAMER 17.5MM	1

FREEDOM PCK CASE 3

STEM REAMERS & TRIALS - BOTTOM

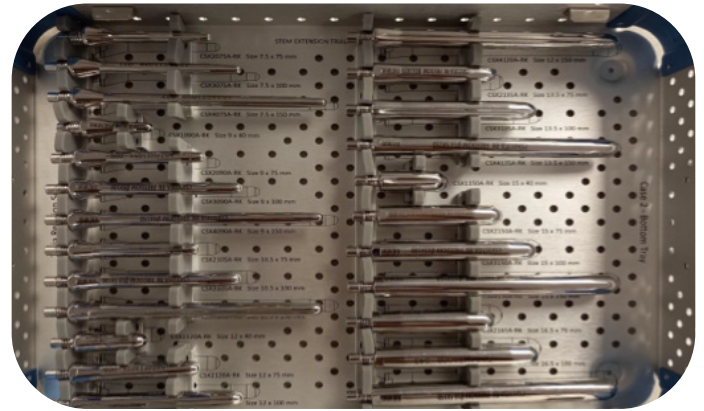

PART #	DESCRIPTION	QTY
CSX2075A-RK	STEM TRIAL 7.5MM X 75MM	1
CSX3075A-RK	STEM TRIAL 7.5MM X 100MM	1
CSX4075A-RK	STEM TRIAL 7.5MM X 150MM	1
CSX1090A-RK	STEM TRIAL 9MM X 40MM	1
CSX2090A-RK	STEM TRIAL 9MM X 75MM	1
CSX3090A-RK	STEM TRIAL 9MM X 100MM	1
CSX4090A-RK	STEM TRIAL 9MM X 150MM	1
CSX2105A-RK	STEM TRIAL 10.5MM X 75MM	1
CSX3105A-RK	STEM TRIAL 10.5MM X 100MM	1
CSX4105A-RK	STEM TRIAL 10.5MM X 150MM	1
CSX1120A-RK	STEM TRIAL 12MM X 40MM	1
CSX2120A-RK	STEM TRIAL 12MM X 75MM	1
CSX3120A-RK	STEM TRIAL 12MM X 100MM	1
CSX4120A-RK	STEM TRIAL 12MM X 150MM	1
CSX2135A-RK	STEM TRIAL 13.5MM X 75MM	1
CSX3135A-RK	STEM TRIAL 13.5MM X 100MM	1
CSX4135A-RK	STEM TRIAL 13.5MM X 150MM	1
CSX1150A-RK	STEM TRIAL 15MM X 40MM	1
CSX2150A-RK	STEM TRIAL 15MM X 75MM	1
CSX3150A-RK	STEM TRIAL 15MM X 100MM	1
CSX4150A-RK	STEM TRIAL 15MM X 150MM	1
CSX2165A-RK	STEM TRIAL 16.5MM X 75MM	1
CSX3165A-RK	STEM TRIAL 16.5MM X 100MM	1
CSX4165A-RK	STEM TRIAL 16.5MM X 150MM	1

FREEDOM PCK CASE 3

ADDITIONAL STEM REAMERS & TRIALS



PART #	DESCRIPTION	QTY
EDXX180A-RK	DISTAL REAMER 18MM	1
EDXX185A-RK	DISTAL REAMER 18.5MM	1
EDXX190A-RK	DISTAL REAMER 19MM	1
EDXX195A-RK	DISTAL REAMER 19.5MM	1
EDXX200A-RK	DISTAL REAMER 20MM	1
EDXX205A-RK	DISTAL REAMER 20.5MM	1
EDXX210A-RK	DISTAL REAMER 21MM	1
CSX2180A-RK	STEM TRIAL 18MM X 75MM	1
CSX3180A-RK	STEM TRIAL 18MM X 100MM	1
CSX4180A-RK	STEM TRIAL 18MM X 150MM	1
CSX2200A-RK	STEM TRIAL 20MM X 75MM	1
CSX3200A-RK	STEM TRIAL 20MM X 100MM	1
CSX4200A-RK	STEM TRIAL 20MM X 150MM	1

FREEDOM PCK CASE APK

ADDITIONAL PRIMARY KNEE INSTRUMENTS

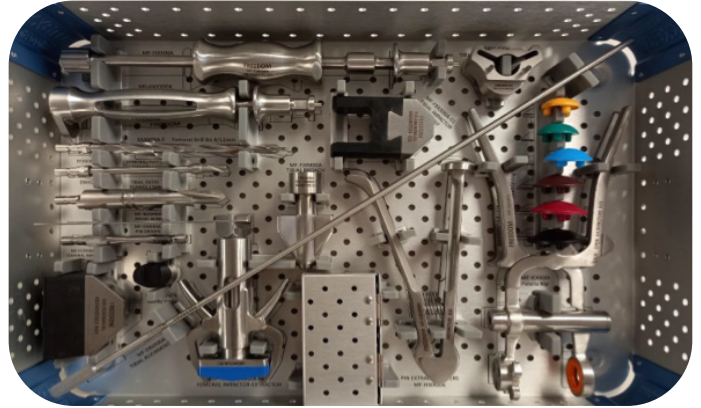

PART #	DESCRIPTION	QTY
MF-FIXX00A	SLAP HAMMER	1
MF-HAXX00K	UNIVERSAL HANDLE	1
EAXX00A-F	FEMORAL DRILL BIT 8/12MM	1
EEXX06A-F	FEMORAL/PATELLA LUG HOLE BIT	1
EBXX17A-F	PCK TIBIAL ENTRY REAMER 17MM	1
MF-BAXX00G	ANGEL WING	1
MF-EIXX00A	PIN DRIVER	1
MF-FCXX00A-01	FEMORAL IMPACTOR	1
MF-FBX-M00A-01	TIBIAL INSERT IMPACTOR	1
MF-DBXX00A	TIBIAL ALIGNMENT ROD	1
MF-HCXM00K	FEMORAL IMPACTOR-EXTRACTOR	1
MF-FJXM00A	TIBIAL BROACH	1
MF-FBXX00A-01	TIBIAL IMPACTOR ALL POLY	1
-	PIN TRAY	1
MF-DAXX00F	THREADED PIN	2
MF-DAXX00E	LONG PIN	2
MF-DAXX00D	HEADED PIN	2
MF-HIXX00A	PIN EXTRACTOR PLIERS	1
MF-BBXM00H	TIBIAL BROACH HOUSING	1
MK-CEXX25A	PATELLA PROVISIONAL 25 MM	1
MK-CEXX28A	PATELLA PROVISIONAL 28 MM	1
MK-CEXX31A	PATELLA PROVISIONAL 31 MM	1
MK-CEXX34A	PATELLA PROVISIONAL 34 MM	1
MK-CEXX37A	PATELLA PROVISIONAL 37 MM	1
MK-CEXX40A	PATELLA PROVISIONAL 40 MM	1
MF-IEXX00I	PATELLAR NIP	1

Pursue Life

For more information about Freedom® Knee System please contact your local representative.

Find us on social media



@maxxortho

Download the Maxx Ortho App for more product information:



Download on the
App Store



GET IT ON
Google Play

Search for Maxx Ortho

Freedom® PCK® Revision Knee System



Maxx Orthopedics, Inc.
2460 General Armistead Ave, Ste 100
Norristown, PA 19403 USA



Carefully read all instructions and be familiar with the surgical techniques prior to use.

Please see the package insert for complete device description, product selection information, indications, contraindications, precautions, adverse effects, warnings, materials, sterilization and patient guidance associated with Freedom Total Knee® System

CAUTION: THIS DEVICE IS RESTRICTED TO SALE BY OR ON THE ORDER OF A LICENSED PHYSICIAN

WARNING: THIS DEVICE IS INTENDED FOR CEMENTED USE ONLY

Freedom Knee® is manufactured by Maxx Orthopedics, Inc. FREEDOM, FREEDOM KNEE, PCK, RENEW, Pursue Life and Think Outside the Box are Registered Trademarks of Maxx Orthopedics, Inc.

©2025 Maxx Orthopedics. All rights reserved.

MXO-MP00023 R07 05/25

maxx
orthopedics

www.maxxortho.com